

# STAGESTAR

D8+ ENTERTAINMENT HOIST



# FEATURES AND BENEFITS

Lightweight and easy to transport, the CM® StageStar™ D8+ electric chain hoist is built for safety and reliability in any entertainment application. Built on decades of entertainment lifting expertise, the StageStar is built to last and is easy to maintain if needed.

**Capacity:**  
250 kg

## ROBUST BODY

Engineered for the demanding needs of the entertainment industry, CM StageStar hoists feature a robust body and durable fiber reinforced composite covers that can withstand the most rigorous applications.

## EASY TO SERVICE

This hoist is an easy-to-maintain, modular-designed device. The gear box is maintenance-free for the whole lifetime of the hoist. All critical parts like the chain guide and load wheel, electronic board, the brake, and motor, are easily accessible with standard tools.

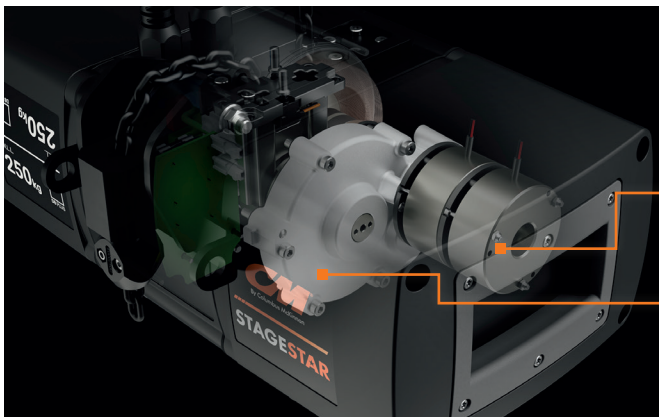

## D8 PLUS RATING

In standard configuration, the motors are rated D8 plus in accordance with SQ P2 (2018).

Double brake is standard with CM StageStar D8 Plus electric chain hoists.

## EXTENDED LIFETIME

Lifetime lubricated gearbox means no oil change is required.

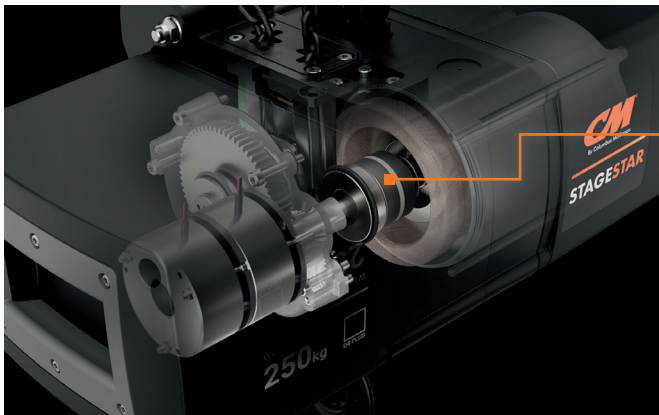

## SAFETY

Slip clutch protects all load-bearing components from overload. Designed to guarantee a safe, permanent connection between the load and the brake to meet higher safety requirements.

## ADAPTABLE EXTENSIONS

- Limit switches
- Gear shaft for back-up limit switches or encoders

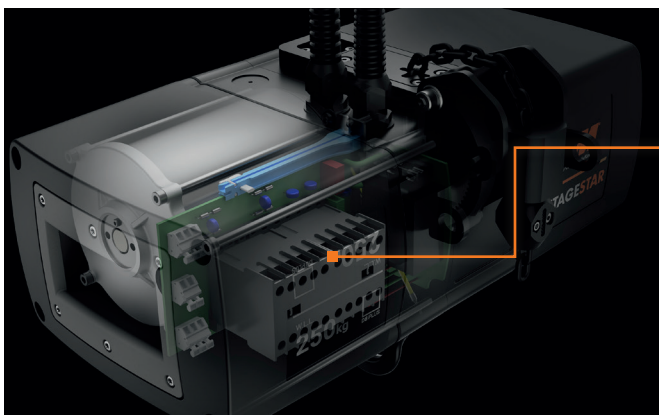

## EASY TO SERVICE

Resetting the slip clutch and inspecting the brake is simple and time-saving.

Direct control or low-voltage (24v) control available. The electronic board is easily accessible.

## OTHER FEATURES:

- Swivel hook
- Operating voltage 230/400 V, 3 ph, 50 Hz
- Robust chain guide inlet to prevent chain jams
- Robust covers with ergonomic carry handles

# DIMENSIONS & TECHNICAL DATA

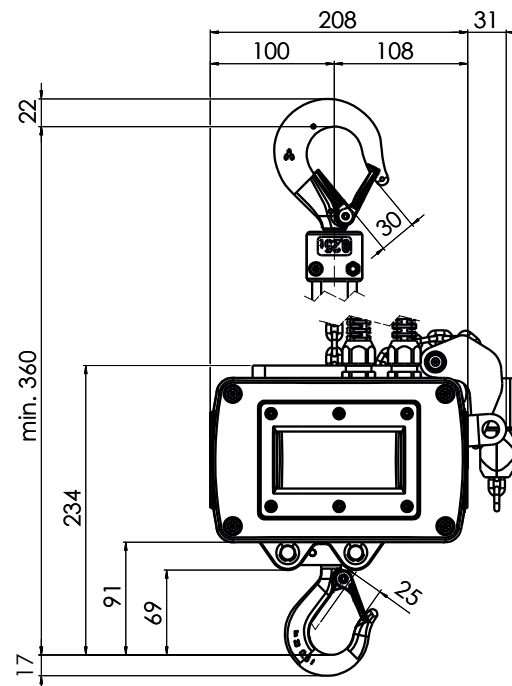
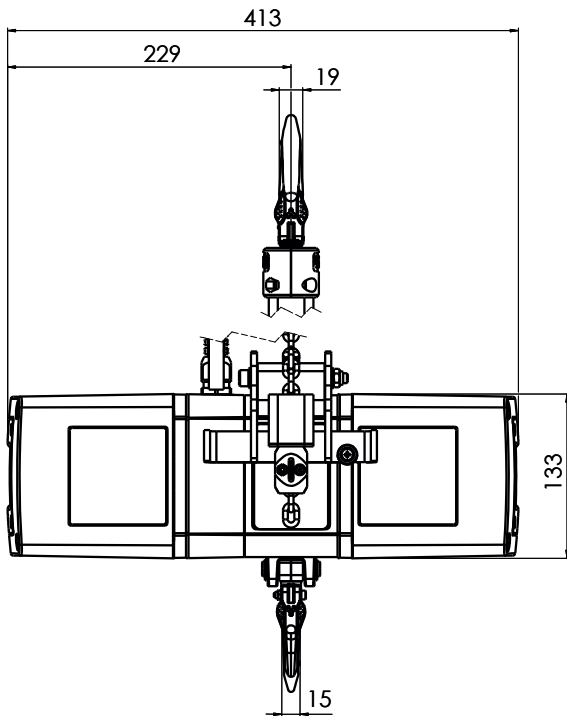

\* Dimensions in mm



## TECHNICAL DATA

Model	CM StageStar
Direct Control Product Code	192105358*
Low Voltage Control Product Code	192105359*
Capacity	250 kg (D8 Plus)
Lifting Speed at 50 Hz	4 m/min
Chain Pitch	4.0 x 12.2 mm
Power at 50 Hz	0.25kW
Current at Full Load 230 V, 50 Hz	1.30 A
Current at Full Load 400 V, 50 Hz	0.75 A
Weight Without Chain	17 kg

\* Hoists with 18m chain (other chain lengths can be ordered at request), include swivel body-mounted hook, ready-mounted chain bag holder, 0.5 m power cord (LVC units include 0.5 m wired control cable).



**CMCO**  
INTELLIGENT MOTION



**A.C. Entertainment Technologies**

World Class Products | World Class Service

UK & International Sales  
Tel: +44 (0)1494 446000

Northern UK Sales  
Tel: +44 (0)113 255 7666

sales@ac-et.com  
www.ac-et.com