



Chroma-Q™ Twin FX Gobo Rotator

**Part No:
CHGR2FX**

S P E C I F I C A T I O N S H E E T

V 1.2

DESCRIPTION

The gobo rotator shall provide operation of two gobos counter-rotating at a variable speed of 0.25-20rpm, and accept any combination of one or two 'B' size metal or glass gobos.

The rotator shall be designed to fit in the gobo gate or iris slot of ETC Source4, Strand SL, Altman Shakespeare and Selecon Pacific ellipsoidal fixtures.

The rotator shall provide a choice of adjustable motion effects.

The rotator shall be designed to operate in stand alone mode from a 24VDC power supply.

The rotator shall be equipped with a diagnostic section on the LED display showing power, data signal and level presence.

FEATURES

- Fits the ETC Source 4, Strand SL, Altman Shakespeare and Selecon Pacific fixtures.
- Can be operated with one single or two counter-rotating gobos for stand-alone operation.
- Variable speed, bi-directional 0.25-20RPM standard rotation.
- Adjustable dynamic effects include:
 - tick-tock
 - pendulum
 - shimmer
 - accelerate
 - decelerate
 - fire
 - water
 - rotate-pause
 - shake-pause
- Supplied complete with a separate 100-240VAC power supply.
- Dedicated remote speed control available.
- Plug and play.
- Ultra quiet.

OVERALL SPECIFICATIONS

Net dimensions:	Width (A): 119mm / 4.7" Height (B): 249mm / 9.8" Depth overall (C): 69mm / 2.7" Depth body (D): 13mm / 0.5"
Net Weight:	0.9kg / 2lbs
Shipping dimensions:	Width: 135mm / 5.3" Height: 315mm / 12.4" Depth: 90mm / 3.5"
Shipping weight:	1.2kg / 2.6lbs
Gobo size:	B
Suitable for:	ETC Source4, Strand SL, Altman Shakespeare and Selecon Pacific
Speed range:	0.25-20rpm
Colour:	Black
Power:	100-240VAC, 50-60Hz
Power connector:	IEC chassis male

ORDERING INFORMATION

Model
Chroma-Q Twin FX Gobo Rotator

Part No.
CHGR2FX

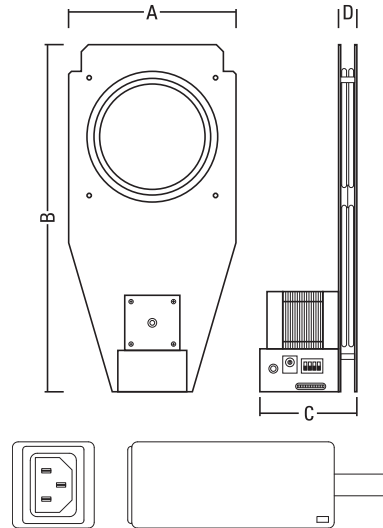

Separate PSU supplied with unit



www.chroma-q.com



HQ, UK & International Sales
A.C. Entertainment Technologies Ltd.
Tel: +44 (0)1494 446000
Fax: +44 (0)1494 461024
sales@ac-et.com
www.ac-et.com

Northern UK Sales
A.C. Entertainment Technologies Ltd.
Tel: 0113 255 7666
Fax: 0113 255 7676
acnorth@ac-et.com
www.ac-et.com

North American Sales
A.C. Lighting Inc.
Tel: 416-255-9494
Fax: 416-255-3514
northamerica@aclighting.com
www.aclighting.com

Asian Sales
A.C. Lighting Asia KK
Tel: +81 (0)48-475-9377
Fax: +81 (0)48-475-9355
sales@aclighting.jp
www.aclighting.jp

Chroma-Q and all associated product names are recognised trademarks, for more information visit www.chroma-q.com/trademarks. The rights and ownership of all trademarks are recognised. The information contained herein is correct at the time of printing, however as we are constantly refining our product range we reserve the right to change the specification without notice. E60E.