



Chroma-Q™ Color Split™ LED Fixture

**Part No:
CHCS2**

S P E C I F I C A T I O N S H E E T

V 1.9

DESCRIPTION

The LED fixture unit shall be suitable for creating a wide range of fixture configurations, including battens, blinders, footlights, side fills, cyclorama floods, truss toners, discreet set piece lighting and interior architectural lighting.

The fixture shall utilise side-by-side LED cells to provide split colour effects.

The fixture shall utilise wide-angle and narrow-angle beam technology.

The fixture shall offer a choice of HSI, RGB, RGB (*Magic Amber) and RGBI (*Magic Amber) control modes.

The fixture shall provide a highly efficient 620 hot lumen output in a compact design.

The fixture shall feature a built-in stand alone mode.

The fixture shall feature a built-in power supply.

The fixture shall be manufactured from extruded lightweight material.

FEATURES

- Modular construction - can be used to create battens, blinders, footlights, side fills, cyclorama floods, truss toners etc.
- Dual side-by-side RGBA cells - for single colour or dramatic split colour effects.
- Advanced split beam technology - for a very even, soft beam output (similar to a Fresnel fixture) & a smooth colour wash from top to bottom of a surface without hotspots.
- Smooth, linear dimming curve.
- Single or dual LED cell control in HSI, RGB, 3 channel RGB (Magic Amber*) and 4 channel RGBI (Magic Amber*).
- Magic Amber* modes automatically & seamlessly blend the Amber alongside the RGB LEDs for a better range of warmer colours & superior colour rendition index (up to 82%).
- Extremely bright (620 hot lumen output) - ideal for even the most demanding lighting environments and applications.
- Exceptional colour brightness and light output levels.
- Built-in power supply - for maximum versatility.
- Can be controlled via built-in standalone mode or connected to additional equipment via DMX.
- All-purpose design - create custom LED lighting solutions for a wide variety of applications (including touring, rental, TV, theatre, tradeshow and indoor architectural) using stock of one fixture.
- Comprehensive range of fixing accessories available - for wall, floor, truss, stand & vertical hanging.
- Heavy gauge anodized aluminium extrusion, lightweight but extremely robust.
- Compact design with cable management.
- Active cooling system - safe, efficient & optimal operation in most conditions.
- L70 up to 50,000 hours - very low maintenance and cost of ownership.

OVERALL SPECIFICATIONS

Net dimensions (without fixings):	Width (A): 250mm / 9.8" Height (B): 136mm / 5.3" Depth (C): 125mm / 4.9"
Net weight:	2.38kg / 5.3lbs
Shipping dimensions:	Width: 172mm / 6.8" Height: 293mm / 11.5" Depth: 127mm / 5"
Shipping weight:	2.99kg / 6.6lbs
Power consumption:	90-240V AC, 60W
Hot lumen output:	Red 250 hot lumen Green 375 hot lumen Blue 91 hot lumen Amber 175 hot lumen White 620 hot lumen
LED cells:	2
LEDs per cell:	4 x RGBA
Total LEDs:	32
Beam dispersion:	23°
Lamp life:	L70 up to 50,000 hours
IP rating:	IP20
Control types:	Single / dual - HSI, RGB, RGB (*Magic Amber) & RGBI (*Magic Amber)
Standalone mode:	Yes
Built-in effects:	Yes
Mains connector:	PowerCon in/thru
DMX connector in/out:	XLR5 in/thru
Control:	ANSI E1.1 DMX-512A
Cooling fans:	1
Color:	Black anodised
Built-in hardware:	Interlocking system & quick release catches for connecting as battens. 2 x M10 nuts for additional fixings
Accessories included:	Yoke/floor stand

ORDERING INFORMATION

Model	Part No
Chroma-Q Color Split - black	CHCS2
Chroma-Q Color Split - other colours	TBA

ACCESSORIES

Model	Part No
Yoke kit for 3 Color Splits	CHCSTY

*Magic Amber is the term used for the unit's ability to bring in amber when mixing colours that require it.

www.chroma-q.com



HQ, UK & International Sales
A.C. Entertainment Technologies Ltd.
Tel: +44 (0)1494 446000
Fax: +44 (0)1494 461024
sales@ac-et.com
www.ac-et.com

Northern UK Sales
A.C. Entertainment Technologies Ltd.
Tel: 0113 255 7666
Fax: 0113 255 7676
acnorth@ac-et.com
www.ac-et.com

North American Sales
A.C. Lighting Inc.
Tel: 416-255-9494
Fax: 416-255-3514
northamerica@aclighting.com
www.aclighting.com

Asian Sales
A.C. Lighting Asia KK
Tel: +81 (0)48-475-9377
Fax: +81 (0)48-475-9355
sales@aclighting.jp
www.aclighting.jp

All Chroma-Q LED products are licensed by Color Kinetics. Chroma-Q and all associated product names are recognised trademarks, for more information visit www.chroma-q.com/trademarks. The rights and ownership of all trademarks are recognised. The information contained herein is correct at the time of printing, however as we are constantly refining our product range we reserve the right to change the specification without notice. EGOE.



**Chroma-Q™ Color Split™
LED Fixture**

**Part No:
CHCS2**

S P E C I F I C A T I O N S H E E T

V 1.9

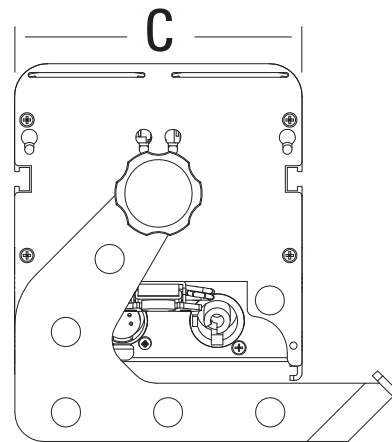
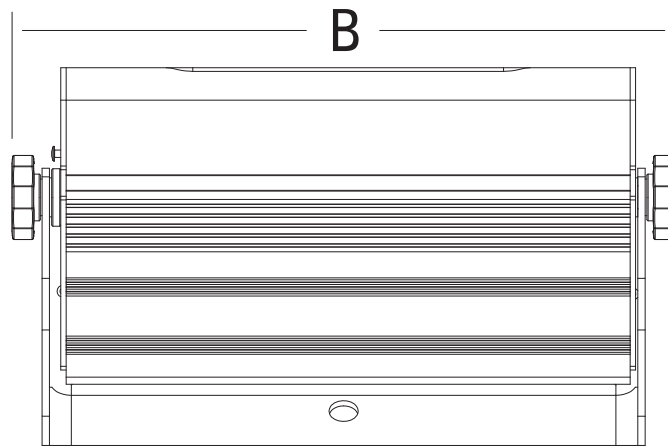
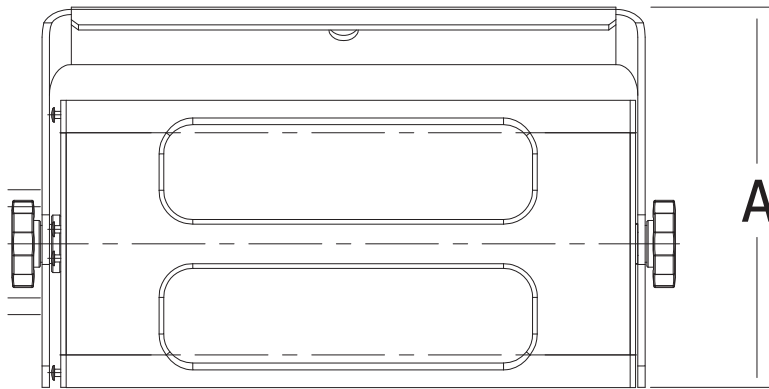

*Magic Amber is the term used for the unit's ability to bring in amber when mixing colours that require it.

CE
www.chroma-q.com



HQ, UK & International Sales
A.C. Entertainment Technologies Ltd.
Tel: +44 (0)1494 446000
Fax: +44 (0)1494 461024
sales@ac-et.com
www.ac-et.com

Northern UK Sales
A.C. Entertainment Technologies Ltd.
Tel: 0113 255 7666
Fax: 0113 255 7676
acnorth@ac-et.com
www.ac-et.com

North American Sales
A.C. Lighting Inc.
Tel: 416-255-9494
Fax: 416-255-3514
northamerica@aclighting.com
www.aclighting.com

Asian Sales
A.C. Lighting Asia KK
Tel: +81 (0)48-475-9377
Fax: +81 (0)48-475-9355
sales@aclighting.jp
www.aclighting.jp

All Chroma-Q LED products are licensed by Color Kinetics. Chroma-Q and all associated product names are recognised trademarks, for more information visit www.chroma-q.com/trademarks. The rights and ownership of all trademarks are recognised. The information contained herein is correct at the time of printing, however as we are constantly refining our product range we reserve the right to change the specification without notice. EGOE.