



# Chroma-Q™ Universal Colour Changer

## Part No: CHCQMU

### SPECIFICATION SHEET

### V 1.4

#### DESCRIPTION

The scroller shall provide control of a user customised internal gel string containing from 2 to 24 frames.

The scroller shall be compatible with lighting fixtures up to 203mm / 8" lens aperture and be adjustable to different fixtures using its variable mounting plate.

The scroller shall be controlled via the industry standard ANSI E1.11 USITT DMX 512-A protocol. Power and data transfer shall be provided by an XLR 4-pin connector. The DMX system shall allow for group or individual addressing of units.

The scroller shall be addressed using manual switches located on the unit. These switches shall be used to select mode of operation.

The scroller shall have two internal cooling fans and diagnostic LED indicators showing Power, DMX signal presence and DMX level.

The scroller shall provide DMX control of scrolling speed and cooling fan speed.

The scroller shall have a gel saver mode to increase longevity of the gel strings.

**Note:** To simplify the choice of power supply we use the "PU" (Power Unit) to calculate the load requirements of the Chroma-Q system. For example a PS08 will supply up to 8PU's, so you can plug-in 5 Chroma-Q Universal (5 x 1.5PU = 7.5PU) into a PS08.

#### FEATURES

- Fits 500-2000W fixtures, with a lens of up to 203mm / 8" in diameter.
- Universal mounting system adjusts between 147-275mm / 6.8-10.8" and requires no additional mounting plates.
- Suitable for up to 50° beam angle (without light loss).
- DMX control for fan speed, scrolling speed, gel saver mode and reset.
- 2 - 24 frames.
- Highly reliable design.
- Rugged but lightweight construction.
- Easily accessible working components.
- Industry standard connectors.
- Fully compatible with other Chroma-Q models & accessories.
- Operation status indicators.
- Automatic self-calibration.

#### ORDERING INFORMATION

| Model                             | Part No. |
|-----------------------------------|----------|
| Chroma-Q Universal colour changer | CHCQMU   |

#### OVERALL SPECIFICATIONS

|                 |   |
|-----------------|---|
| Net dimensions: | width (A): 359mm / 14.1"<br>height (B): 345mm / 13.6"<br>depth (C): 80mm / 3.1" |
| Net weight:     | 2.5kg / 5.5lbs inc. brackets  |

#### OVERALL SPECIFICATIONS cont.

|                      |   |
|----------------------|---|
| Shipping dimensions: | width: 380mm / 15.0"<br>height: 355mm / 14.0"<br>depth: 90mm / 3.5" |
| Shipping weight:     | 2.5kg / 5.5lbs  |
| Rear aperture:       | 203mm / 8"  |
| Front aperture:      | 260mm / 10.3"   |
| Frame capacity:      | 2-24 colours  |
| Colour media:        | Pro Color HT+, Rosco Supergel & GAMcolor recommended                |
| Cooling:             | 2 fan design  |
| Cooling speed:       | Multiple speeds   |
| Addressing:          | Digitally via 3 push buttons and LED display                        |
| Working Voltage:     | 24VDC (+/- 10%)   |
| Power consumption:   | 1.5PU (see note below)  |
| Protocol:            | ANSI E1.11 USITT DMX 512-A  |
| Body material:       | Aluminium   |
| Colour:              | Black powder coat (white available)                                 |
| Mounting plate:      | Universal mounting system fits 147mm-275mm fixtures (5.8"-10.8")    |
| Safety cable:        | Included  |
| Connectors:          | XLR-4 (male) in & XLR-4 (female) through                            |

#### ACCESSORIES

| Model  | Part No. |
|--|----------|
| Chroma-Q 2PU DMX/Power Unit                        | PS02     |
| Chroma-Q 8PU DMX/Power Unit                        | PS08     |
| Chroma-Q Magic Box 12PU DMX/Power Unit             | MBPS12   |
| "Theatre" colour scroll (specify no of frames)     | GST      |
| "Rock & Roll" colour scroll (specify no of frames) | GSR      |
| High temperature clear scroll tape                 | ST       |
| Various lengths of Tourflex® Datasafe™ cable       |          |

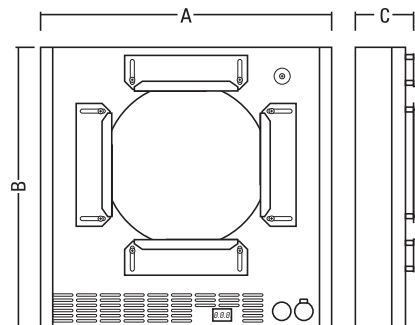

[www.chroma-q.com](http://www.chroma-q.com)



**HQ, UK & International Sales**  
A.C. Entertainment Technologies Ltd.  
Tel: +44 (0)1494 446000  
Fax: +44 (0)1494 461024  
sales@ac-et.com  
www.ac-et.com

**Northern UK Sales**  
A.C. Entertainment Technologies Ltd.  
Tel: 0113 255 7666  
Fax: 0113 255 7676  
acnorth@ac-et.com  
www.ac-et.com

**North American Sales**  
A.C. Lighting Inc.  
Tel: 416-255-9494  
Fax: 416-255-3514  
northamerica@aclighting.com  
www.aclighting.com

**Asian Sales**  
A.C. Lighting Asia KK  
Tel: +81 (0)48-475-9377  
Fax: +81 (0)48-475-9355  
sales@aclighting.jp  
www.aclighting.jp