

# JANDS EVENT

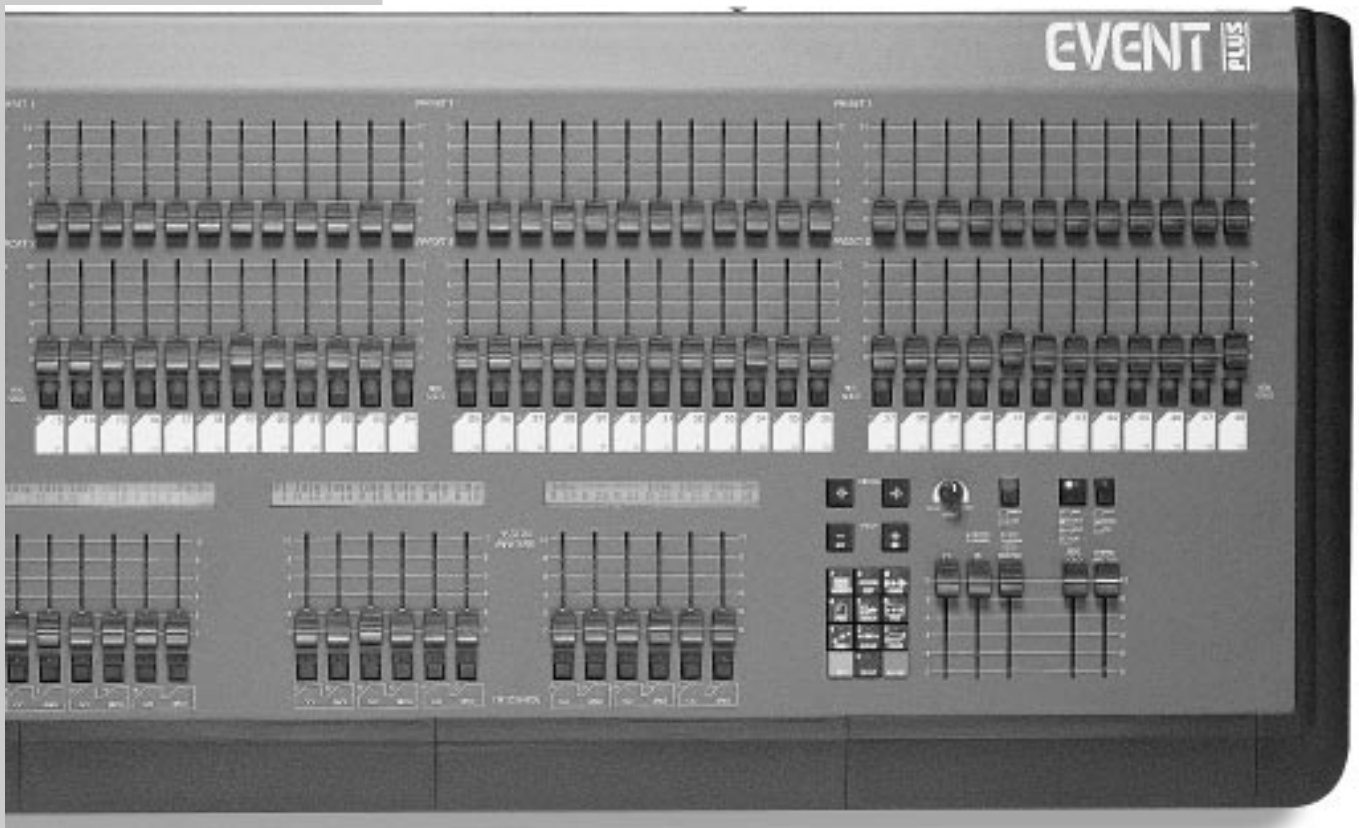

## **Event V3 Operating Manual**

# Introduction

---

JANDS, one of the world's leading lighting console manufacturers, now offers the EVENT PLUS series of control consoles. Equipped with all the outstanding features of the original Event, the EVENT PLUS offers many new functions and features. Available in two configurations: 48 and 60 channels, each with 24 Assign masters and 2 Presets, the EVENT PLUS features a "first" for JANDS - single preset operation. In today's lighting rigs there is an increasing emphasis on moving lights and colour scrollers both of which quickly use up available channels. The EVENT PLUS's ability to operate as a single preset board means that it can offer up to 120 channels for programming and playback.

Recording on the EVENT PLUS has been simplified with the addition of One Touch Recording, simply hold the Record button and press an Assign master flash button to store a memory to that Assign fader. To make labelling and the addition of fade times easier, Memories that have been recorded are tagged with an "r" in the Memory menu.

The EVENT PLUS Page consists of 20 Memories and 1 Chase, the remaining 3 Assign faders are set to control 2 fixed Memories and 1 fixed Chase. However it is possible to edit the standard Page setup or to Assign any combination of crossfade Stacks, Chases or Memories to the 24 Assign faders. A further enhancement to the Assign master section is the ability to use the Hold master as a submaster controlling all 24 Assign faders.

Output from the console is available via a standard DMX-512 socket or through optional analogue Socapex connectors, using either method it's possible to use the onboard softpatch to create up to 3 different channel to dimmer patching tables.

The EVENT PLUS is a further extension of the commitment to ongoing development which makes JANDS lighting consoles the most exciting and innovative products available today.

## General Description

1.00	General Description Of Major Parts .....	10
2.00	How The Event Stores Information .....	11
3.00	The Event Menu System .....	13

## Getting Started

4.00	Hardware Setup .....	16
	Connecting Power .....	17
	Connecting Desklights .....	17
	Connecting a VDU .....	15
	Connecting MIDI Device .....	17
	Connecting a Slave Console .....	17
	Turning the Power On .....	17
5.00	Software Setup .....	18
	Setting the Number of Console Channels .....	18
	- <i>To Increase the Number of Channels Available On the Consoles</i> ....	18
	Patch .....	20
	- <i>To Patch Dimmers to the Consoles</i> .....	20
	- <i>Patching Multiple Dimmers to a Consoles</i> .....	20
	- <i>Storing Changes Made in Patch</i> .....	20
	Labelling Patch .....	22
6.00	Manual Controls .....	23
	The Presets / Presets Faders / Flash Buttons .....	23

## Creating Memories & Chases

7.00	Memories .....	26
	Recording Memories .....	26
	- <i>METHOD 1: Record and Point</i> .....	28
	- <i>METHOD 2: Using the Menu</i> .....	30
	Labelling a Memories .....	30
	Playing back a Memory .....	31
	Editing a Memory .....	32
	- <i>METHOD 1: Record and Point</i> .....	32
	- <i>METHOD 2: Using the Menu</i> .....	34

## Table of Contents

---

<b>8.00</b>	<b>Chases .....</b>	<b>36</b>
	Recording a Chase-Using the Menu .....	36
	Labling a Chase .....	38
	Setting the Chase Direction .....	39
	Setting the Chase Speed .....	40
	Adding Attack / Decay to the Chase .....	41
	Adding a Dipless Crossfade Between Steps (X) .....	42
	Playing Back a Chase .....	43
	Recall a Chase - Introduction to Assign .....	44
	- <i>METHOD 1: Change Page</i> .....	44
	- <i>METHOD 2: Assign the Chase</i> .....	46
	Editing a Chase .....	48
	- <i>METHOD 1: Using the Menu</i> .....	48
	- <i>METHOD 2: Using Assign Flash Button</i> .....	50
	Deleting a Step .....	52
	Adding a Step .....	53
	Recording Changes Made in Edit .....	53

## Managing Memories & Chases

---

<b>9.00</b>	<b>Pages .....</b>	<b>56</b>
	Page Make-Up .....	56
	Loading a New Page .....	56
	Freeze .....	58
	Labelling a Page .....	60
<b>10.00</b>	<b>Assign .....</b>	<b>61</b>
	Assign Memory .....	62
	Assign Chase .....	64
	Assign Stack .....	66
	Special Feature - Assign Edit .....	66
<b>11.00</b>	<b>File .....</b>	<b>68</b>
	Saving a File .....	68
	Loading a File .....	68
	Labelling a File .....	70
<b>12.00</b>	<b>Stacks .....</b>	<b>71</b>
	Control File .....	71
	- <i>NEXT Fields</i> .....	71
	- <i>INFADE / OUTFDE (Outfade) Fields</i> .....	71
	- <i>Delay Field</i> .....	72
	Changing the NEXT Field .....	72
	- <i>Changing the NEXT Field - Memory</i> .....	72

- Changing the NEXT Field - Chase .....	74
Infade/Outfade - Adding Fade Times .....	76
- Adding Fade Times to a Memory .....	76
- Adding Fade Times to a Chase .....	78
Adding Delay Time .....	80
- Adding Delay Times to a Memory .....	80
- Adding Delay Times to a Chase .....	82

## Control Functions - Playback

<b>13.00 Playback .....</b>	<b>86</b>
Controls .....	86
- Preset Faders .....	86
- Assign Masters .....	86
- Flash Buttons .....	86
- LCD Windows .....	87
Controlling Memories .....	87
- Assign Masters .....	87
- LCD Windows .....	87
Controlling Chases .....	87
- Assign Masters .....	87
- Flash Buttons .....	88
- To Change the Operation of the Chase Flash Button .....	88
- LCD Windows .....	88
Controlling Stacks .....	88
- METHOD 1: Using the Assign Stack Menu .....	89
- METHOD 2: Using the Stack Menu/Assign Faders .....	89
Playback of a Stack .....	89
- Stack Controls .....	89
- Assign Master Faders .....	90
- Go / Back Buttons .....	90
- LCD Windows .....	90
Clear Output From a Stack .....	90
Taking Manual Control of a Fade .....	90
- Taking Manual Control Fade When a Fade is Not Running .....	91
Altering the Playback Order .....	91
The SMaster / Hold Master .....	92
- To Set the Operation of the Hold / SMaster .....	92
- SMaster as Assign Faders Master .....	94
- SMaster as Hold Master .....	94
- SMaster as Manual Crossfade Master .....	94
- SMaster as Memory / Chase Control .....	94
<b>14.00 Overall Master Controls .....</b>	<b>95</b>
P1 and P2 Faders .....	95
- Reversing the P2 Master fader .....	96
Add / Solo Master Switch .....	98
DBO Switch .....	98
- To Chang the Operation of the DBO Switch .....	98
Add / Solo Fader .....	99
Grand Master Fader .....	99
Rate Control .....	99

## Table of Contents

---

### Advanced Features

---

<b>15.00</b>	<b>Advanced Control</b> .....	<b>102</b>
	Build .....	102
	To see the changes in a Build Memory .....	103
	Other Build Menu Features .....	104
	Edit Memory .....	105
	- <i>Restoring theatrically-Using Edit Memory Menu</i> .....	105
	Edit Page .....	106
	- <i>Changing the Make-up of a Page</i> .....	106
	Edit File .....	109
	- <i>Changing the Default File Settings</i> .....	109
	- <i>Restoring the Factory Setting for File</i> .....	109
<b>16.00</b>	<b>Restricting Access to Various Menus and Controls</b> .....	<b>110</b>
<b>17.00</b>	<b>Function Keys</b> .....	<b>111</b>
	To Record a Function Key .....	112
	To Play Back a Function Key .....	112
<b>18.00</b>	<b>Advanced Channel Control</b> .....	<b>114</b>
	Setting Channels to Ignore Crossfade Timing .....	114
	- <i>To Set Channels to Ignore Timing</i> .....	114
	Setting Channels to Always Have a Background Intensity-Preheat ....	116
	- <i>To set Channels to Preheat the Filament</i> .....	116
	Setting Channels to Ignore Flash button Solo Operation .....	118
<b>19.00</b>	<b>Advanced Desk Options</b> .....	<b>120</b>
	Setting Default Infade and Outfade Times .....	120
	Changing the Increment Between Memories When Recording .....	122
	Turning the Help Screen On and Off .....	122
<b>20.00</b>	<b>Using the MCard - Option</b> .....	<b>123</b>
	To Open the MCard Menu .....	123
	To Save the Information Recorded in the Event .....	123
	Loading From the MCard .....	123
<b>21.00</b>	<b>Clearing Memories Chases and Patches</b> .....	<b>124</b>
	Clearing Memories .....	124
	Clearing a Stack .....	126
	Clearing Chases .....	126
	Clearing a Patch .....	128
<b>22.00</b>	<b>Copying Memories Chases and Patches</b> .....	<b>130</b>
	Copying a Memory .....	130
	Copying a Chase .....	132
	Copying a Patch .....	132

<b>23.00</b>	<b>Resetting the Console .....</b>	<b>136</b>
	To reset the Console .....	136
<b>24.00</b>	<b>Connecting a Slave Console .....</b>	<b>138</b>
	To Set an Event Console as a Master .....	138
	To Set an Event Console as a Slave .....	138
<b>25.00</b>	<b>Event LCD Displays .....</b>	<b>139</b>
	LCD Control .....	139
<b>26.00</b>	<b>Setting the Intensity of the Desklights .....</b>	<b>140</b>
<b>27.00</b>	<b>Using MIDI to Control the Event .....</b>	<b>141</b>
	To Select the MIDI Menu .....	141
<b>28.00</b>	<b>Connecting an External Monitor to the Event - Option .....</b>	<b>142</b>
<b>29.00</b>	<b>Analogue Output - Option .....</b>	<b>143</b>
<b>30.00</b>	<b>Floppy Disc Drive - Option .....</b>	<b>144</b>
	<b>General .....</b>	
<b>31.00</b>	<b>Maintenance .....</b>	<b>146</b>
<b>32.00</b>	<b>Service .....</b>	<b>147</b>
<b>33.00</b>	<b>Battery Replacement .....</b>	<b>148</b>
	<b>Appendix A .....</b>	
<b>33.00</b>	<b>Event 24 Output Menu Structure .....</b>	<b>150</b>
	<b>Appendix B .....</b>	
<b>34.00</b>	<b>Pin Assignments .....</b>	<b>152</b>
	DMX Connector Wiring .....	152
	Midi Connector Wiring .....	152
	Desklight Connector Wiring .....	152
	Desk Link Cable Wiring .....	153
	Power Connector Wiring .....	153
	Midi Note Table .....	153

## **Table of Contents**

---

# **General Description**

## 1.00 General Description of Major Parts

### 1.10 Manual Control Section

 **Diagram 1A**

This section is used to control the level of individual desk channels. There are 2 faders (Preset 1 and Preset 2) and a Flash button with an inbuilt level indicator per channel. There is also a writing strip below the Flash buttons.

### 1.20 Assign Master Section

 **Diagram 1B**

This section is used to control the playback of Memories, Chases and crossfade Stacks. There are either 12 or 24 Assign Masters (depending on the desk type) and a corresponding number of Flash buttons. The LCDs located above the Assign Master faders display labels for the items being controlled.

### 1.30 Master Section

 **Diagram 1C**

This section includes the Grand Master fader and DBO button, Flash Master fader and selector switch, Preset Master faders, and a Chase rate control. There is also a Hold / SMaster fader and switch.

### 1.40 Menu Control Section

 **Diagram 1D**

The Event menu system is used to enter and modify settings for Memories, Chases, Stacks, Pages and Files while recording and during playback. It is also used to configure the various setup options.

### 1.50 Back Panel

 **Diagram 1E**

All power and control connections are made on the rear of the console. This is also where option panels are fitted. Possible options include:

- \* 60 way analogue output option
- \* 30 way analogue output extender option
- \* MCard option
- \* MCard/VDU (Mono, CGA, EGA)
- \* MCard/VDU (VGA)
- \* Floppy disk drive

**NOTE:** The keyboard and RS 232 Connections on the rear of the Event Plus are for factory use only.

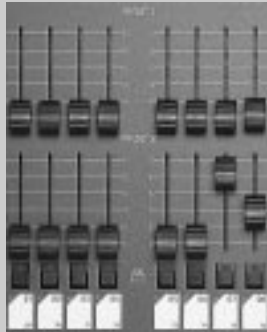

▲ 1A Manual control section

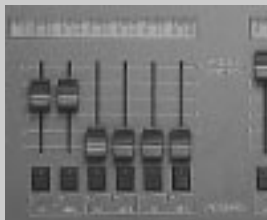

▲ 1B Assign master section



▲ 1C Master section

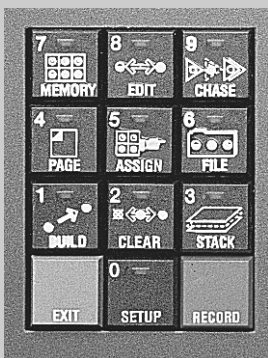

▲ 1D Menu control section

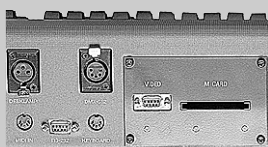

▲ 1E Back panel showing M card option fitted

## 2.00 How the Event Stores Information

 **Diagram 2A**

The information required to control stage lighting instruments is recorded into two basic units: **Memories** and **Chases**.

These basic units can be further organised and grouped to suit a particular performance or show.

- A **Page** consists of a factory-defined group of Memories and Chases.
- A **File** consists of a user-defined group of Memories, Chases and Stacks.
- A **Stack** consists of a sequence of Memories and Chases.

The way these items relate to each other can be seen in diagram 2A.

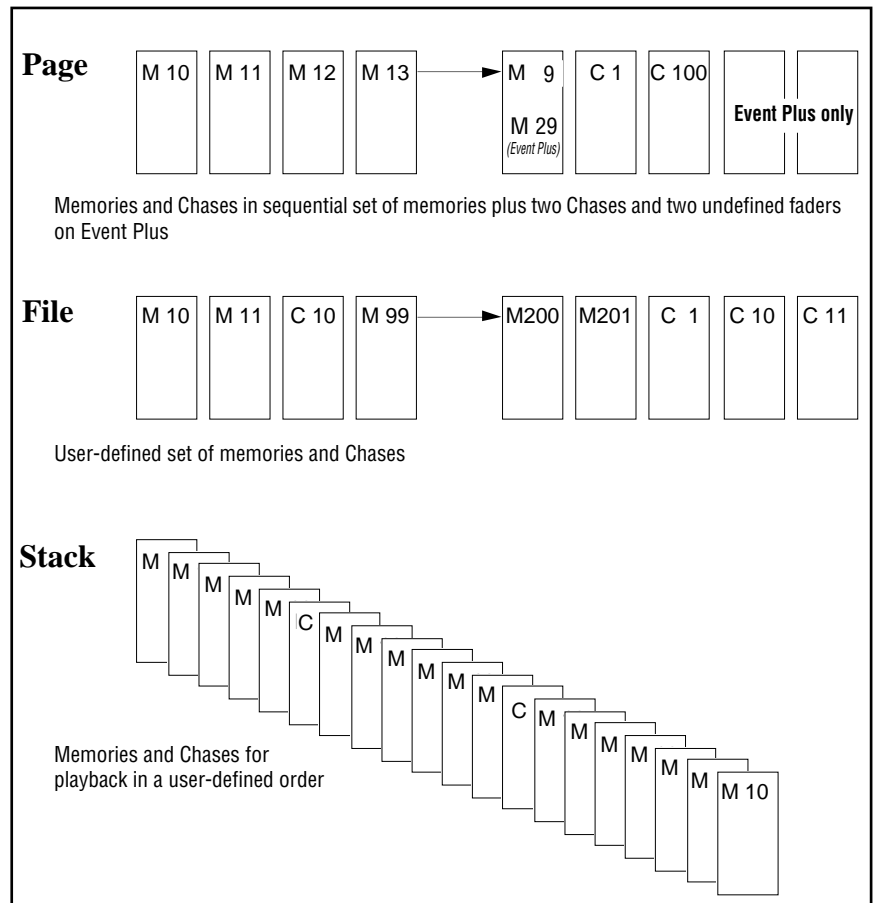

▲ 2A Basic organisation of memories and chases

### 2.10 Memories

A Memory consists of level settings for all of the lights, colour scrollers etc. connected to the console. These level settings range from 0% (when the light is not included in the Memory) through to 100%.

Memories include a label that is displayed on the LCD above the Assign Master faders controlling it, and can also include timing information to control fade rates.

Memories can be assigned one at a time to the Assign Master faders or to a Stack (i.e. a sequence of Memories) that in turn can be assigned to a pair of faders.

### 2.20 Chases

A Chase consists of one or more Steps, each of which contain level settings for all of the lights, colour scrollers etc. connected to the console. These level settings range from 0% (when the light is not included in the Chases) through to 100%.

Chases include a label along with speed, direction and fade information, and can also include timing information to control the fade rate.

Chases can be assigned one at a time to the Assign Master faders or, as part of a Stack, to a pair of Assign Master faders.

### 2.30 Pages

A Page consists of a factory-defined group of Memories and Chases that are loaded to the Assign Master faders. Changing Pages completely replaces the previous set of Memories and Chases. Many operators allocate a Page for each song or act of their show.

### 2.40 Files

A File is like a Page but it can be customised to include any combination of Memories, Chases and even Stacks. A File is created by loading the items you want onto the Assign Master faders and then saving these settings as a File.

### 2.50 Stacks

Memories (and Chases) can be automatically crossfaded in a sequence called a Stack. Initially all Memories (and Chases) are linked together in numeric order - Memory 1 is followed by Memory 2 and so on to Memory 999. This is followed by Chase 1 which is followed by Chase 2 and so on to Chase 999.

However this order can be changed so that Memories follow a non-numeric order. For example Memory 10 might be followed by Memory 20 which is followed by Memory 25.

Stacks can also start and stop anywhere within the available range of Memory numbers. For example you might use Memories 100 through 120 as one Stack and Memories 150 through 200 as another.

Fortunately it's not necessary to decide which Memories you want to include in a Stack when you are first recording. The links that join Memories and Chases can be changed at any time. Likewise, crossfade timing information can be added or altered after a Memory is recorded.

(The use of Stacks is explained more fully in section [12.00](#)).

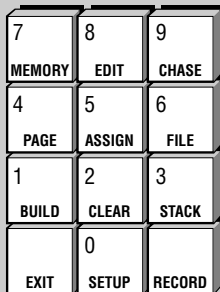

▲ 3A Function keypad

Modify standard console settings  
customise controls & outputs.

▲ 3B Typical help message

SEt DESK Ptch Ctrl Util Pref MCrD  
Up +to⏏ +to⏏ +to⏏ +to⏏ +to⏏ +to⏏

▲ 3C Typical menu field

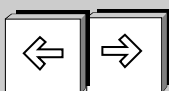

▲ 3D Cursor buttons

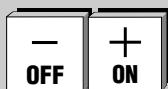

▲ 3E + (On) and - (Off) Buttons

## 3.00 The Event Menu System

Diagram 3A, 3B

All recording, editing, setup and other console functions are controlled via a series of menus. The function keypad along with cursor and value buttons provide the means of opening the menus and entering information.

Since the Event menus are used in many operations it's worth taking some time to familiarise yourself with what the various buttons do and some of the shortcuts that are available.

Whenever one of the ten function buttons : Setup, Build, Clear, Stack, Page, Assign, File, Memory, Edit or Chase is pressed, a menu opens up in the LCD nearest to the function buttons and a help message is displayed in the adjacent LCD .

Some functions like Edit and Assign which are used in conjunction with others use a second button press to select the appropriate menu (i.e. Edit Memory or Edit Chase). Others such as Setup and Clear provide a number of sub-menus to choose from.

### 3.10 Menu Fields

Diagram 3C

Each menu consists of a number of fields. The name of the field appears on the top line of the display and the setting or value for that field appears underneath it. Sometimes a field is used to lead to another menu; in this case, the bottom line shows [ +to⏏ ] which means "Press the + (On) button to open another menu".

**NOTE:** As the cursor is moved, the field the cursor is in changes to UPPERCASE.

### 3.20 Cursor Buttons

Diagram 3D

The left arrow and right arrow buttons are used to move the cursor between the various fields in each menu.

### 3.30 + (On) and - (Off) Buttons

Diagram 3E

The + (On) and - (Off) Buttons are used to change values. The + (On) button will either increase a value or change a setting from Off to On or change a letter/character on a label. Likewise, the - (Off) button will decrease values or change a setting from On to Off. These buttons are also used in a few menus to toggle between several choices, e.g. Setting a Chase to forward or reverse.

The buttons operate in three ways:-

- \* **Press:** The value increases by 1 with the + (On) button or decreases by 1 with the - (Off) button.
- \* **Press and Hold:** The value scrolls up with the + (On) button, or down with the - (Off) button.
- \* **Double Press:** The value snaps to maximum with the + (On) button or to minimum with the - (Off) button. It may take a couple of attempts to double press at a fast enough speed to see this work.

## General Description

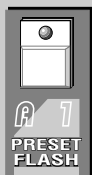

▲ 3F Preset Flash button

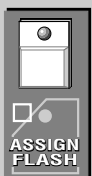

▲ 3G Assign Flash button

MEM: -----	Infade	Outfde
M 10 M 10	0:00	0 0:00 0 More

▲ 3H Memory Menu

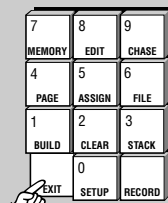

▲ 3I Exit button

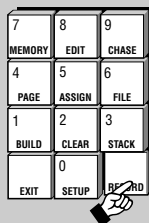

▲ 3J Record button

### 3.40 Entering Numbers Directly to Fields

Once a menu has been opened the function buttons change to a numeric keypad. Numbers can be entered directly into menu fields such as Page number, Memory number and so on.

### 3.50 Entering Labels

#### Diagram 3F, 3G, 3H

The Memory, Chase, Page, File and Patch menus all have a Label field. The section circled in Diagram 3H shows the Memory menu with the Label field highlighted (the other menus all have the Label field in the same position). The Event automatically supplies a label for each field (in the diagram shown as M10) but the Preset/Assign Flash buttons can be used to type a label of your choice. Below each Flash button there is a character marking.

#### Example:

- Open the Memory menu and use the right arrow button to move the cursor to the first character position of the label field.
- Type BLUE WASH or something similar. If you make a mistake just use the cursor buttons to move back and type over the incorrect character. The square box marking below the third (fifth on Event Plus) Assign Master Flash button represents a space. You can also use the numeric keypad to type numbers.

### 3.60 Exit Button

#### Diagram 3I

The Exit button is used to back out of the menu system. If a top level menu is open, pressing Exit closes the menu system. If a nested menu is open pressing the Exit button makes the display return to the previous (higher level) menu.

If no menu is open the Exit button can be used to show the Event software version number.

### 3.70 Record Button

#### Diagram 3J

When a menu is open the Record button is used to save new or modified intensity settings.

If no menu is open the Record button can be used to change the LCD window from showing Memory and Chase labels to showing Memory and Chase numbers. This feature is useful if you have given names to Memories and Chases and need to know what number they were, or need to see the steps of a Chase sequencing.

# Getting Started

## 4.00 Hardware Setup

### 4.10 Connecting Power

Plug the socket end of the power cord into the IEC power receptacle located on the rear face of the Event. The other end of the power cord should be plugged into a 3-pin grounded outlet. It is important that the Event is electrically grounded; if in doubt, contact a licensed electrician.

### 4.20 Connecting the Output to a Dimmer

Event provides **two** methods of connection to dimmer systems. The DMX output is standard on all consoles. Optional Socapex output panels can also be fitted to the console to provide 0 - 10V wire-per-channel analogue outputs.

#### *METHOD 1. DMX-512 Output*

Connect from the console's DMX output to the DMX input on the dimmer rack. Check the dimmer instruction manual for details on selecting DMX channels and looping the DMX line to other dimmer racks.

Up to 512 dimmer channels can be controlled in this way.

#### *METHOD 2. Analogue Outputs (Option)*

Connect from the console's Socapex outputs to the dimmer rack input. Up to eight Socapex connectors can be fitted to a console to provide up to 240 channels of dimmer control.

#### **4.30 Connecting Desklights**

Desklights are available as an optional accessory. Only 12V Littlite or compatible desklights with 3-pin Cannon XLR type connectors should be used (for wiring see [Appendix B](#)).

#### **4.40 Connecting a VDU**

Connect from any Monochrome, CGA, EGA or VGA monitor to the connector on the option panel. Two video output options are available to suit the above range of monitors (for wiring see [Appendix B](#)).

#### **4.50 Connecting a MIDI Device**

The Event console is equipped with a MIDI input (there is no through connector). Use a standard MIDI cable to connect from the MIDI device to the MIDI In connector on the backpanel (for wiring see [Appendix B](#)).

#### **4.60 Connecting a Slave Console**

Any Jands Stage 12, ESP II or Event console can be slaved to the Event.

Connect from the DMX output of the slave console to the MIDI input of the main console. This cable should be wired as detailed (for wiring see [Appendix B](#)).

#### **4.70 Turning the Power On**

Once all connections have been made the console can be turned on using the mains power switch located next to the power lead input.

## 5.00 Software Setup

### 5.10 Setting the Number of Console Channels

#### 5.11 To increase the number of channels available on the console

 **Diagram 5A**

One of the most powerful features of the Event is its ability to work as a single preset board outputting double the number of channels normally available. In applications where colour scrollers or moving lights are being controlled this feature greatly extends the usefulness of the console. An Event 24, for instance could control 48 colour scrollers.

**NOTE:** WIDE should be turned on before any Memories or Chases have been recorded. When WIDE is turned on the number of available Memories is reduced.

Once a console has been set to WIDE the Preset 2 faders are used to control the higher numbered channels. For example, on an Event 48 the Preset 2 faders would control channels 49 to 96. The Preset 2 Master fader is disabled.

When Wide mode is on an indicator appears at the far right end of the right LCD window. W1 indicates the desk is in Wide mode with a single preset, W2 indicates the desk is in Wide mode with dual presets.

- ❶ Press the Setup button to open the Setup menu.
- ❷ Move the cursor to the DESK field and press the + (On) button to open the Set Desk menu.
- ❸ Move the cursor to the WIDE field and press the + (On) button to open the Set Desk Wide menu.
- ❹ In the Set Desk Wide menu move the cursor to the WIDE field and press the + (On) button to change the field to On.
- ❺ Move the cursor to the CHANS field - this field will have automatically changed to double the number of channels [i.e. a 60 channel console will have changed to 120. Type in any number of channels to a maximum of 252 (120 on Event)].

**NOTE:** If more than double the number of channels are selected in step 5 you will need a slave console to control the extra channels (see [Section 24.00](#)).

- ❻ Move the cursor to the PSETS field and change this field to Single to allow all the Preset faders on the console to be used as a single preset. On an Event 60 this means you will have 120 console channels with the top preset controlling channels 1-60 and the bottom preset controlling channels 61 - 120.
- ❼ Move the cursor to the CONFIRM field. If all the settings are correct press the + (On) button to confirm the changes.
- ❽ Press Exit to close the Set Desk Wide menu.
- ❾ Press Exit once more to close the Setup menu completely.



PT	----	Ch#	Dim:At	Dim:At	Dim:At
1	M 10	1	1 FF	NC FF	NC FF

▲ 5B Patch menu

## 5.20 Patch

 **Diagram 5B**

The Event will control up to 512 dimmer channels via the DMX output or 240 channels via the optional analogue output panels. The Patch menu allows these dimmer channels to be patched at any level to the console channels. There are three Patch tables available.

Normally when you turn the console on Channel 1 will be patched to dimmer channel 1, Channel 2 will be patched to dimmer channel 2 and so on for all the console channels. To change this you use the Patch menu.

**TIP:** It is possible, for example, to set one Patch which includes all dimmers for the main act, and a different Patch which might not include all dimmers for the support act. Similarly if a light was knocked out of focus during the show the Patch could be used to reduce the level of its dimmer to 0 so the light would not come on at any time.

Changing the Patch number will make the new Patch active immediately - be careful about making any changes during a show.

## 5.21 To Patch Dimmers to the Console

 **Diagram 5C**

- 1 Press the Setup button to open the Setup menu.
- 2 Move the cursor to the PTCH field and press the + (On) button to open the Patch menu.
- 3 Press the + (On) button or Keypad to change the Patch number in PT field (there are 3 Patches available - 1, 2 and 3).
- 4 Move the cursor to the CH# field and set a console channel number (i.e. 1).

**NOTE:** Patch tables 1d/2d/3d display Patches 1/2/3 in reverse, i.e. a dimmer number is specified and the control channel is shown.

- 5 Move the cursor to the DIM: field and set a dimmer number (i.e. 1).
- 6 Move the cursor to the AT field and set the intensity (normally FF or 100%).

## 5.22 Patching Multiple Dimmers to a Channel

- 7 The CH#, DIM: and AT fields are repeating fields, so it is possible to patch several dimmers to the one desk channel. However a dimmer can only be patched to one channel at a time.

## 5.23 Storing Changes Made in Patch

- 8 When all changes to a patch have been made, press the Record button to save these changes and leave the Patch menu. If you press the Exit key you are prompted to either save the changes by pressing the + (On) button or to abandon them by pressing the - (Off) button.
- 9 Press Exit to close Patch menu.
- 10 Press Exit again to close Setup menu.

(For information on Clearing a Patch or setting a Null Patch see [Section 21.00](#)).



## 5.30 Labelling a Patch

 **Diagram 5C + 5B**

The label field is used to name a Patch. An eight character label can be typed using the flash buttons for characters and the function keypad for numbers.

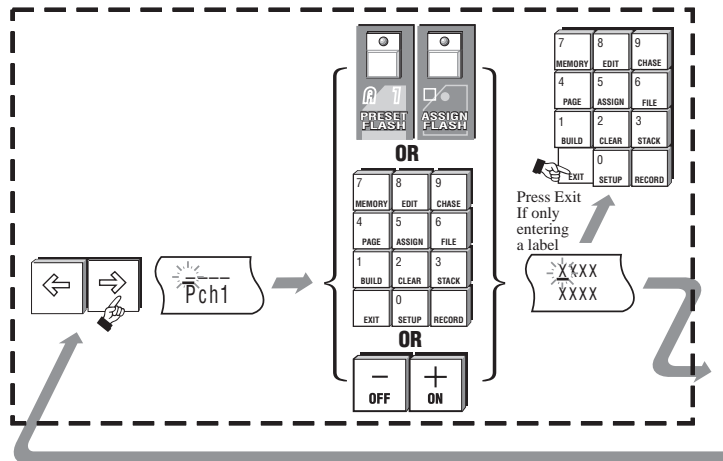

▲ 5C Labelling a Patch

## 6.00 Manual Controls

### 6.10 The Presets

 Diagram 6A

The Preset faders are used to set up lighting levels during a show and while programming Memories and Chases. It is possible to run a show entirely on the presets but generally these controls are used for recording or to make impromptu changes to the stage lighting.

### 6.20 Preset Faders

 Diagram 6A, 6B, 6C

There are two rows of Presets faders on the Event. The top row of faders is Preset 1 and the bottom row is Preset 2. These faders can be used to smoothly fade a light to the desired level. The output level produced by the Preset faders is dependent on the level of the P1 (or P2) Master and the Grand Master fader.

#### Example:

- Bring the Grand Master and P1 Master faders to 10 (100%).
- Move the Channel 1 Preset fader to 100% and you should see the lights connected to that channel fade up to full level.
- Now fade up Channel 2 to 5 (50%). Check that the lights connected to Channel 2 are at about 50% level.
- Finally fade the P1 Master down and up to see how it scales the Channel Preset faders.

### 6.30 Flash Buttons

 Diagram 6D, 6E

Flash buttons are located below each Channel and Assign master fader. They perform three functions:

- \* **Flash:** The buttons are used to momentarily flash a channel to the level set by the Add/Solo Master fader. The type of operation of the Flash button depends on the setting of the Add / Solo Master switch.
- \* **Inhibit:** To prevent a channel from appearing in any output, hold the Flash button down and press the DBO button. Repeat this procedure to cancel inhibit. When a channel is inhibited, the channel LED and DBO LED flash together.
- \* **Text:** When a menu is opened and with the cursor in the Label field, the Flash buttons are used to type various characters as marked on the front panel.

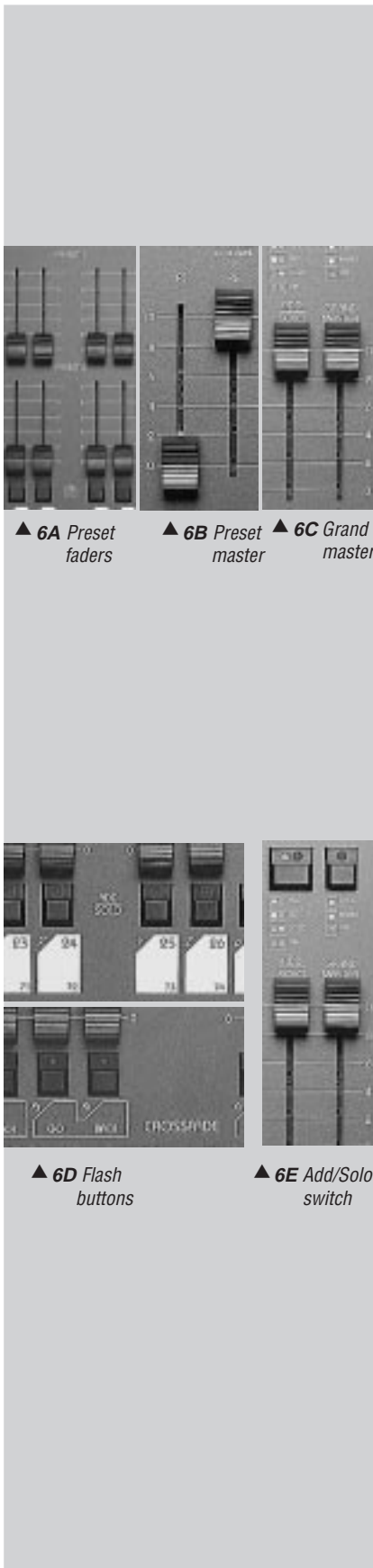

## Getting Started

---

# **Creating Memories & Chases**

### 7.00 Memories

This section explains the steps involved in recording a Memory. Recording Chases is detailed in the next section, but the procedures are very similar to that involved in recording Memories.

If you want to try these procedures, be sure that you have patched the console (see [Section 5.00](#)) and are able to fade lights up and down using the Preset faders.

#### 7.10 Recording a Memory

A Memory records the level settings of all the Event channels (some lighting boards refer to Memories as scenes or cues). The Event offers **two** alternative methods of recording Memories.

##### 7.11 METHOD 1: Record and Point

 **Diagram 7A**

- 1 Use the Preset faders (and any other console controls) to set up the lighting output required.
- 2 Press and hold the Record button

**NOTE:** The LCDs above the Assign Masters show the Memory numbers being controlled by the faders.

- 3 While holding the Record button down press the Assign Flash button beneath the Memory number to be recorded.
- 4 A message displays on the LCD showing the percentage of available Memory space that has been used and how much remains.
- 5 Release Record button.

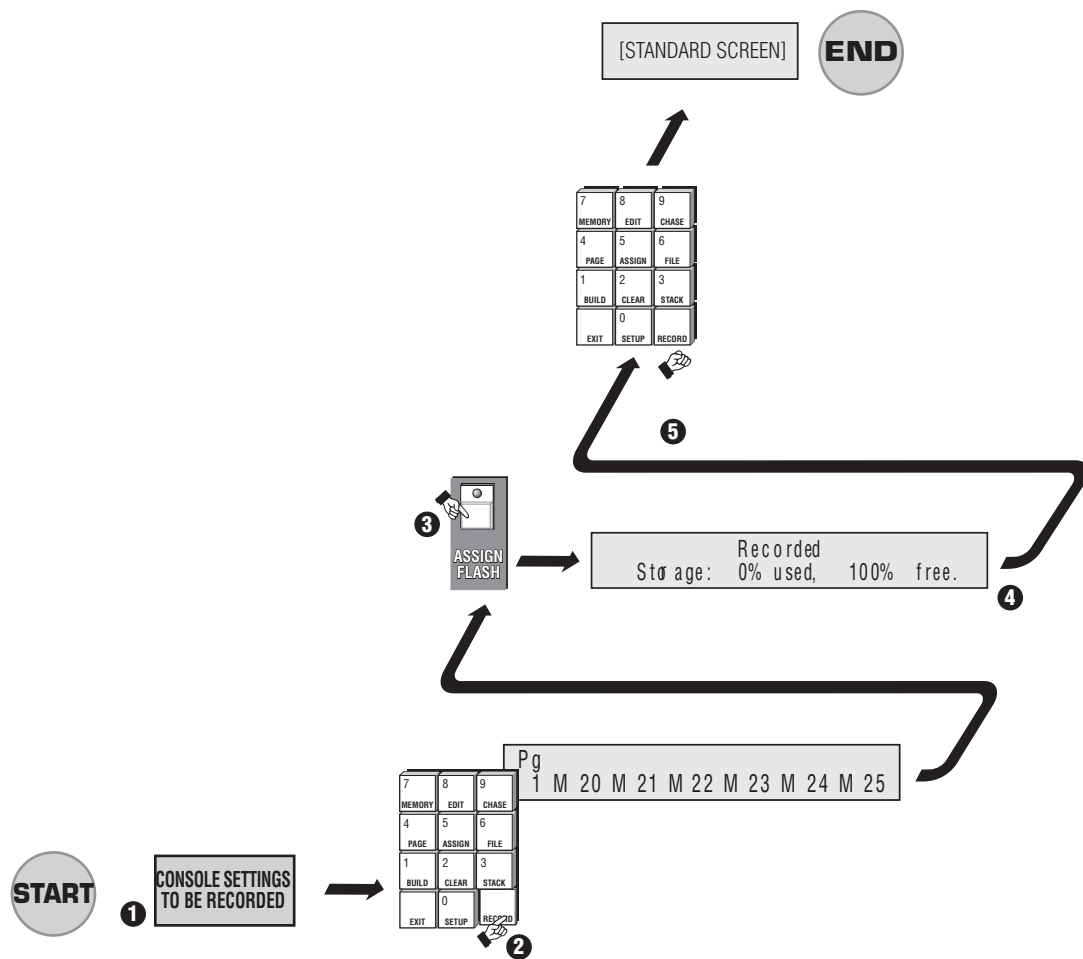

▲ 7A Recording a Memory - Record and Point (Method 1)

### 7.12 METHOD 2: Using the Menu

 **Diagram 7B**

- ❶ Press the Memory button.
- ❷ Use the Preset faders (and any other console controls) to set up the lighting output required.
- ❸ Enter the Memory number (0 - 999) to be recorded using the numeric keypad or alternatively use the + (On)/- (Off) buttons to change the displayed Memory number.

**NOTE:** The cursor automatically moves to the Label field if a three digit number is entered.

- ❹ Press the Record button (a message displays on the LCD shows the percentage of available memory space that has been used and how much remains).
- ❺ Another Memory can now be recorded by repeating steps ❷ , ❸ and ❹ (see Note below).
- ❻ Press the Exit button if no more Memories are to be recorded.

**NOTE:** The number in the Memory menu automatically advances by 1 when the Record button is released. This allows a number of Memories to be recorded without leaving the Memory menu.

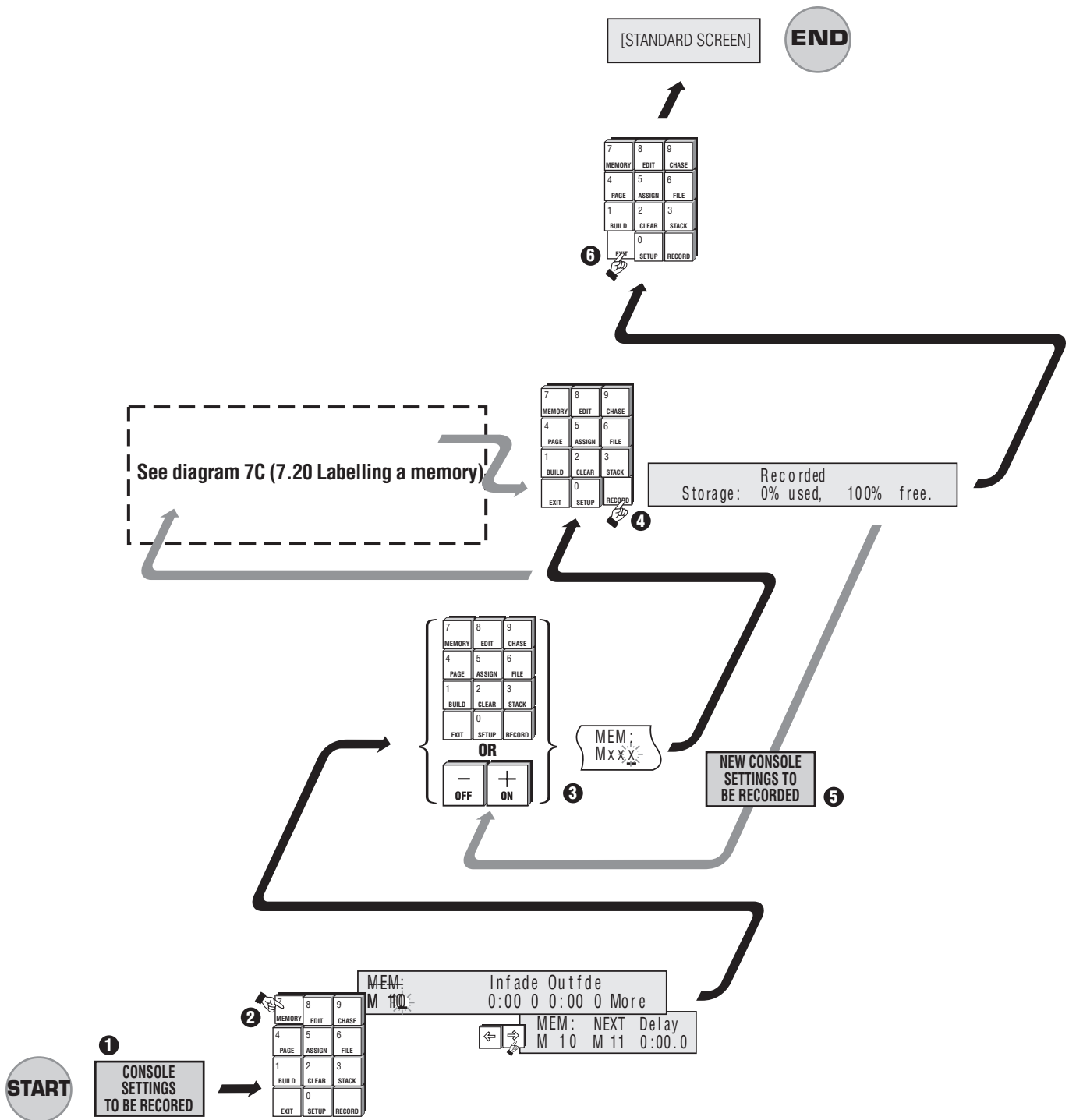

▲ 7B Recording a Memory - Using the Menu (Method 2)

# Creating Memories & Chases

## 7.20 Labelling a Memory



Diagram 7C + 7B

Memories can be labelled to allow easy identification of their contents. For example, Memories might be labelled BLUE WASH or DRUM SOLO; whenever these Memories are loaded to the Assign Masters their labels are displayed in the LCD window above the Assign fader.

1. Press the Memory button.
2. Enter the Memory number (0 - 999) to be labelled using the numeric keypad or alternatively use the + (On)/- (Off) buttons to change the displayed Memory number.

**NOTE:** The cursor automatically moves to the Label field if a 3 digit number is entered.

3. Use the arrow buttons to move the cursor to the Label field (to the right of the Memory number field).
4. Type a label of up to eight characters using the Flash buttons.

**NOTE:** Each Flash button is marked on the front panel with a character (1=A, 2=B etc.). Typing a label will NOT cause lights to flash on at the same time.

5. Press the Exit button if no more Memories are to be labelled.
6. Do NOT press the Record button if you are only entering or changing a label.

**TIP:** Memories can be labelled while they are being recorded (using the menu method) or labelled later by using the Memory menu.

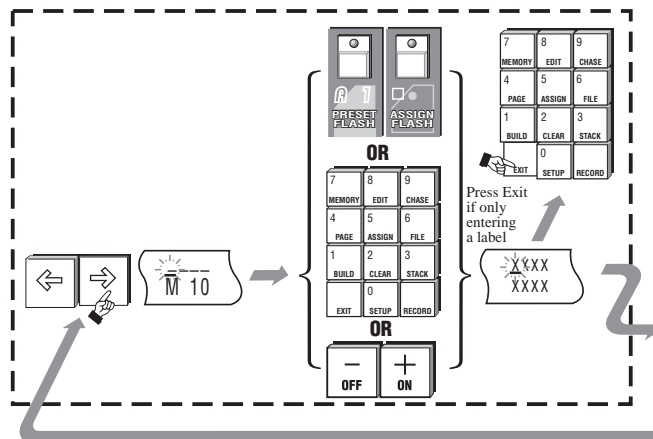

▲ 7C Labelling a Memory

### 7.30 Playing Back a Memory

To see what is recorded so far follow these steps:

1. Pull down all the Preset faders so you can see just what has been recorded in the Memory.
2. Check that you can see the Memory number or the label you gave it in the LCD window above one of the Assign Masters.
3. Move the Assign fader to 100%.

If you do not see anything, check that the Grand Master is at full. If you can not see what you expected try recording again, paying careful attention to the procedures. (For more information on Play Back see [Section 13.00](#)).

### 7.40 Editing a Memory

There are **two** ways to make changes to the channel intensities.

**TIP:** A Memory can be edited to change the levels of channels or groups of channels. Editing can be carried out 'blind', that is, without the changes being seen on stage, or 'live' if that Memory is currently being outputted to the stage (by one of the Assign Masters).

Whenever the EDIT MEMORY menu is opened the Preset faders are disabled from outputting to the stage. However, they can be used to set levels for the item being edited.

#### 7.41 METHOD 1: Record and Point



Diagram 7D

- 1 Press the Edit button.
- 2 Press the flash button beneath the Assign fader controlling the item to be edited.
- 3 Use the Preset 1 (top preset) faders to set new levels for the channels you want to change. To edit a channel this way, the fader first has to be moved to match the existing level of the channel and then moved to the new level. The simplest way to do this is to move the fader from zero to full and then to the new level.
- 4 Press Record button. The LCD will display the percentage of available Memory space that has been used and that which remains, and will return to standard screen after the button is released.

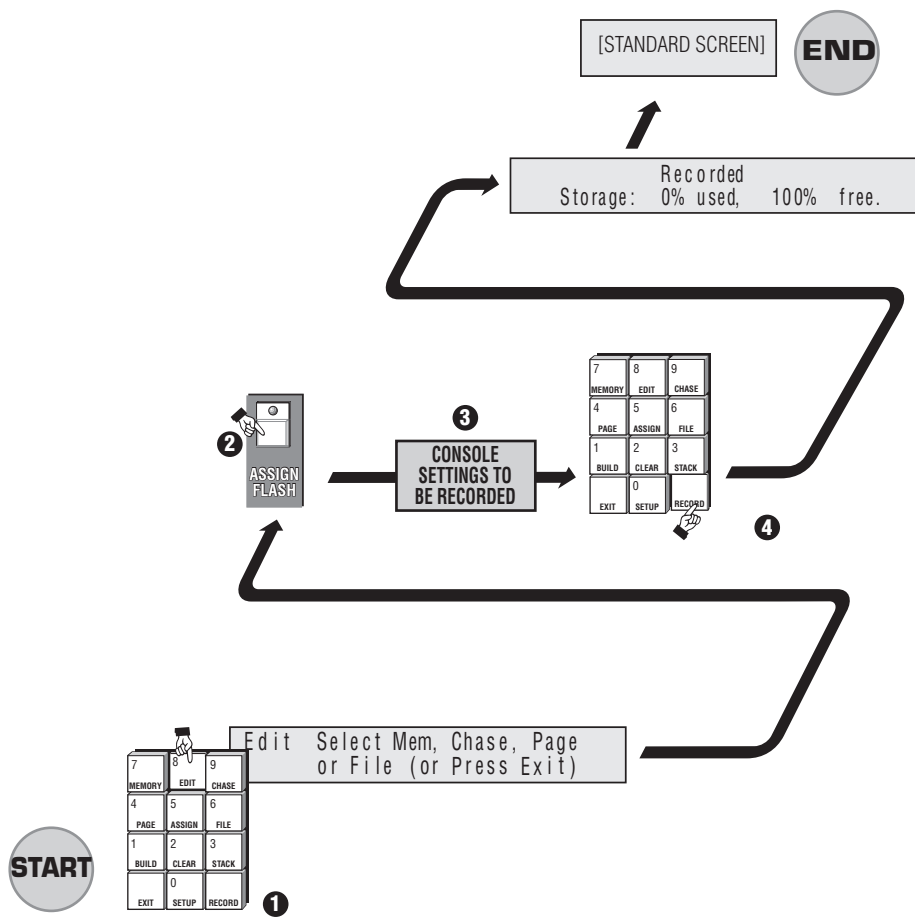

▲ 7D Editing a Memory -Record and Point (Method 1)

### 7.42 METHOD 2: Using The Menu

 **Diagram 7E**

- 1 Press the Edit button.
- 2 Press the Memory button. Enter the Memory number (0 - 999) to be edited.
- 3 Move the cursor to the CH# (channel) field. Use the + (On)/- (Off) button or keypad to enter the new channel number.
- 4 Move the cursor to the TO# field. Use the + (On)/- (Off) button or keypad to enter the new number for the range of channels to be edited.
- 5 Move the cursor to the AT (value) field. Use the + (On)/- (Off) button or keypad to enter the new level values.

**Example:**

*In the menu illustrated in diagram 7E channels 10 through to 15 have been set to 50%.*

**TIP:** As each channel or group of channels is adjusted, using either edit method, the changes are stored temporarily so there is no need to press Record to save each individual change.

- 6 Press the Record button. The LCD will display the percentage of available Memory space which has been used and remains, and will then return to the standard screen after the button is released.



### 8.00 Chases

Chases are recorded in the same way as Memories.

#### 8.10 Recording a Chase - Using The Menu

 **Diagram 8A**

- ❶ Press the Chase button.
- ❷ Use the Preset faders (and any other console controls) to set up the lighting output required for the first step of the Chase.
- ❸ Enter the Chase number (0 - 999) to be recorded.
- ❹ Press the Record button.  
The first step of the Chase is recorded and the Step field automatically changes to the next step number.
- ❺ Set up the lighting output required for the next step of the Chase.
- ❻ Press the Record button.
- Continue recording new steps until the Chase is complete (Max. no. 99).
- ❼ Press the Exit button if no more Chase steps are to be recorded.

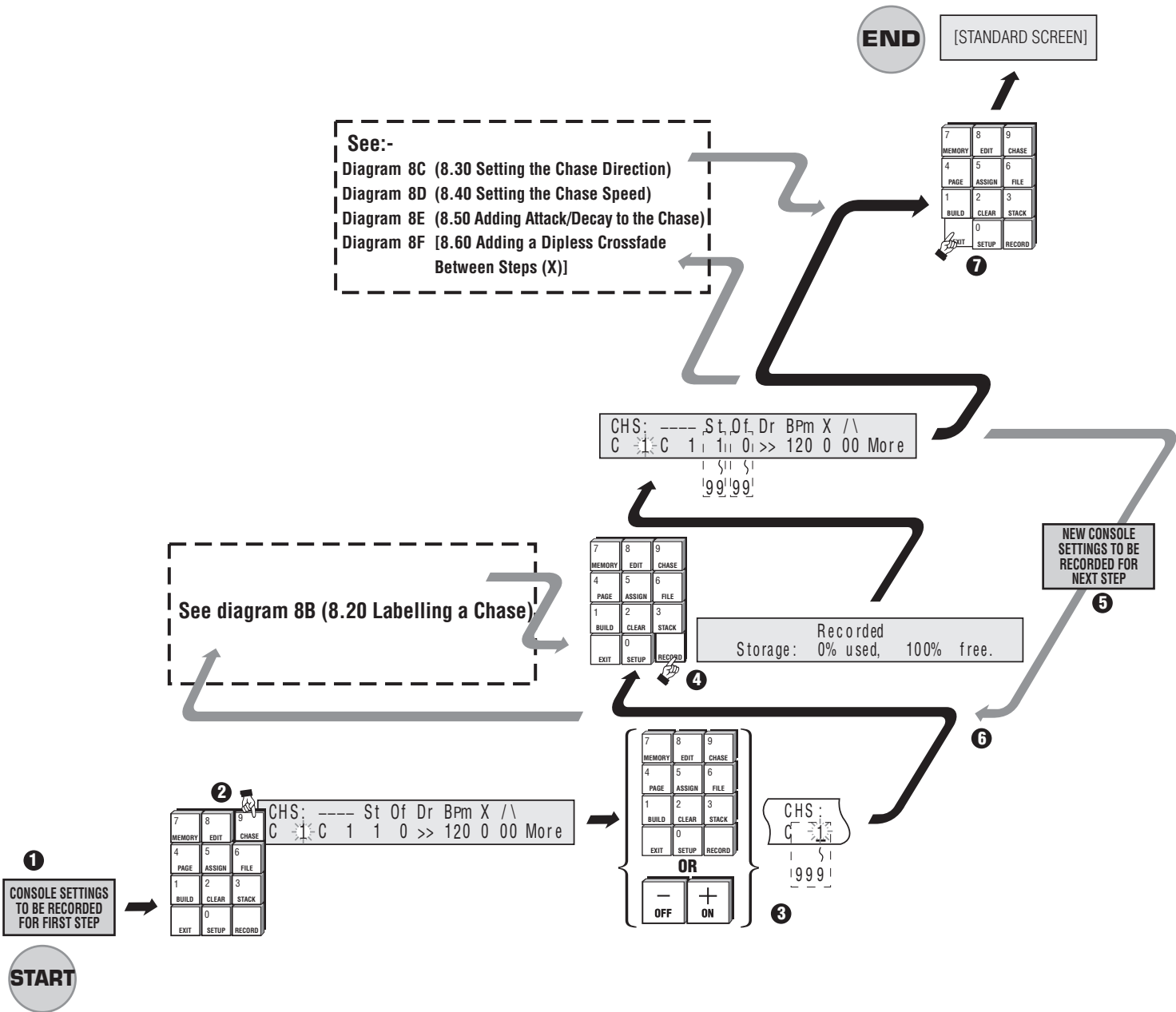

▲ 8A Recording a Chase

## 8.20 Labelling a Chase

 **Diagram 8B + 8A**

Chases can be labelled to allow easy identification of their contents. For example, Chases might be labelled FAST or SLOW and then whenever those Chases are loaded to the Assign Masters the label is displayed in the LCD window above the fader. Chases can be labelled while they are being recorded or at a later time.

1. Move the cursor to the Label field (to the right of the Chase number field).
2. Type a label of up to eight characters using the Flash buttons.
3. Press the Exit button if no more Chases are to be labelled.

**NOTE:** Do NOT press the Record button if only entering or changing a label.

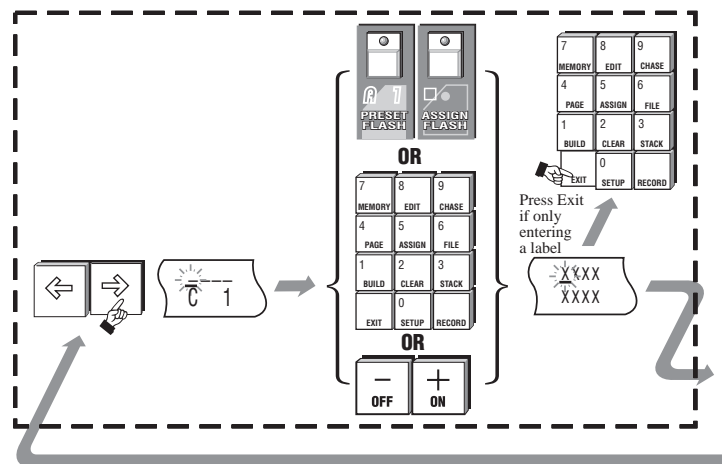

▲ 8B Labelling a Chase

### 8.30 Setting the Chase Direction



#### Diagram 8C + 8A

1. Use the arrow buttons to move the cursor to the DR (Direction) field.
2. Press the + (On) button to change the existing setting. Each press of the + (On) button changes to a new setting. Possible directions are:
  - \* >> - Forward
  - \* <> - Bounce
  - \* << - Reverse
  - \* Rn - Random
3. Press the Exit button.

**NOTE:** Do NOT press the Record button if only entering or changing the Direction.

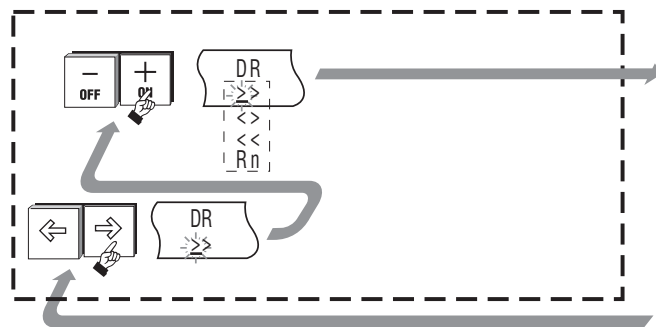

#### ▲ 8C Setting the Chase Direction

### 8.40 Setting the Chase Speed



#### Diagram 8D + 8A

1. Use the arrow buttons to move the cursor to the BPM (Speed in Beats Per Minute) field.
2. Enter a number using the numeric keypad or alternatively use the + (On)/ - (Off) buttons to change the displayed number; 999 is the highest speed. At 0 the Chase is stopped (HH) and can be single stepped using the Chase Flash button.
3. Press the Exit button.

**NOTE:** Do NOT press the Record button if only entering or changing the Speed.

**TIP:** Chase rates can be adjusted using the Rate Control.

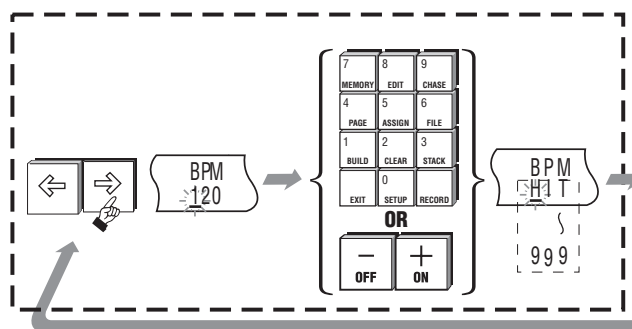

#### ▲ 8D Setting the Chase Speed

## 8.50 Adding Attack / Decay to the Chase



**Diagram 8E + 8A**

1. Use the arrow buttons to move the cursor to the / (Attack) field.
2. Press the + (On) button to turn Attack on (I). Press the - (Off) button to turn it off (O).
3. Use the arrow buttons to move the cursor to the \ (Decay) field.
4. Press the + (On) button to turn Decay on (I). Press the - (Off) button to turn it off (O).
5. Press the Exit button.

**TIP:** Do NOT press the Record button if only entering or changing the Attack / Decay settings.

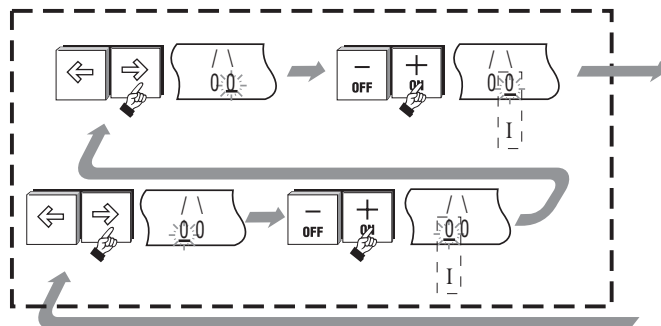

### ▲ 8E Adding Attack / Decay to the Chase

## 8.60 Adding a Dipless Crossfade Between Steps (X)

 **Diagram 8F + 8A, 8G**

1. Move the cursor to the X field and press the + (On) button to turn the crossfade on (I).
2. When X fade is turned on the attack (/) and decay (\) fields are disabled and the menu changes to show the % (percentage) field. The % field sets what percentage of the total crossfade time each step is fully on.

**Example:**

1. Set the Chase speed to 6 BPM (1 step every 10 seconds)
2. Set the % field to 50

*Step 1 takes 2.5 secs to fade in, stays on for 5 secs and then takes 2.5 secs to fade out.*

**TIP:** Xfade is automatically disabled at chase speeds greater 300BPM.

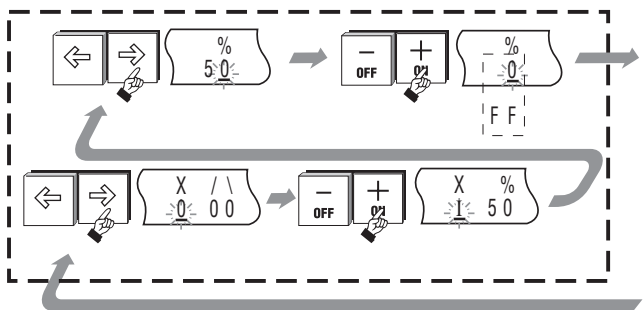

▲ **8F Adding a Dipless Crossfade Between Steps (X)**

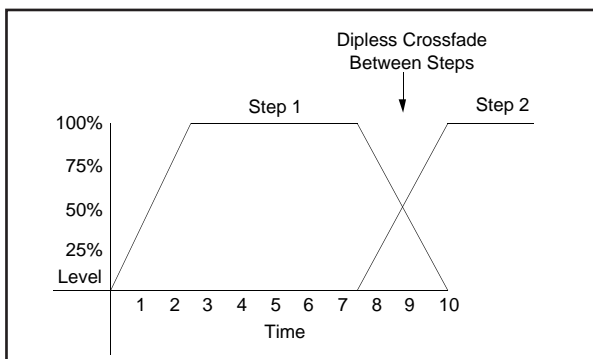

▲ **8G How Crossfade works in a Chase**

## 8.70 Playing Back Chases

To see what is recorded so far, follow these steps:

1. Pull down all the Preset faders so you can see what has been recorded in the Chase.
2. Check that you can see the Chase number or the label you gave it in the LCD window above one of the Assign Faders.
3. Move the Assign fader to 100%.

(For more detail see Playback section [Section 13.00](#))

### 8.80 Recall a Chase - Introduction to Assign

If you are unable to see the Chase number / name above one of the Assign faders you have probably recorded a Chase number that is not part of the Page that is loaded to the Assign Masters. There are **two** ways to get the Chase you want.

### 8.81 METHOD 1: Change Page

 **Diagram 8H**

The Event has Pages preset so that Chase 1 is on Page 1, Chase 2 is on Page 2 and so on. If you've recorded Chase 10 you will want to change to Page 10:

- ① Press Page.
- ② Enter the Page number.
- ③ Move the cursor to the LOAD field.
- ④ Press the + (On) button.

**TIP:** If you don't see anything check that the Grand Master is at full. If you still don't see what you expected try recording again, paying careful attention to the procedures above.

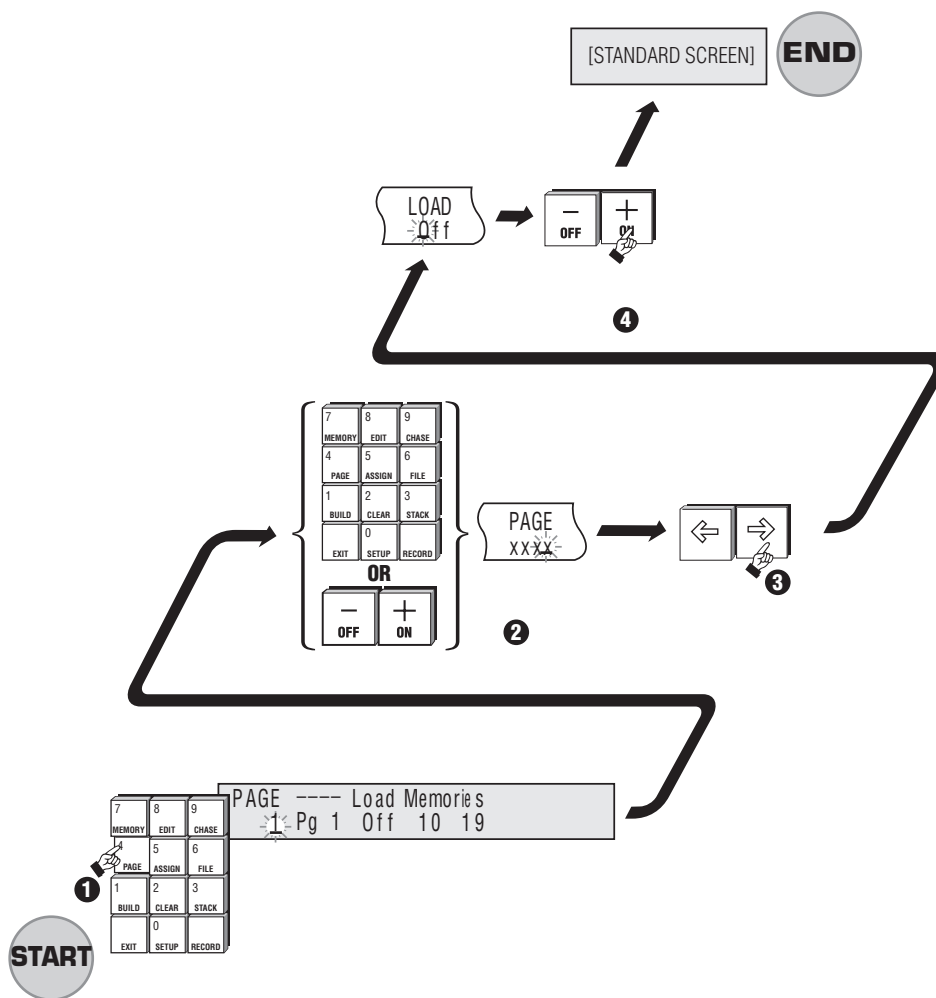

▲ 8H Change Page (Method 1)

### 8.82 METHOD 2 : Assign the Chase

 **Diagram 81**

- 1 Press Assign.
- 2 Press Chase.
- 3 Enter the Chase number - the Event will remember the Chase you have just recorded so this number should be set already.
- 4 Press the Flash button below the Assign fader you want to use to control the Chase.
- 5 Push the Assign fader to fill.

**TIP:** If you do not see anything after following either of the methods described, check that the Grand Master is at full. If you still do not see what you expected try recording again, paying careful attention to the procedures detailed above.

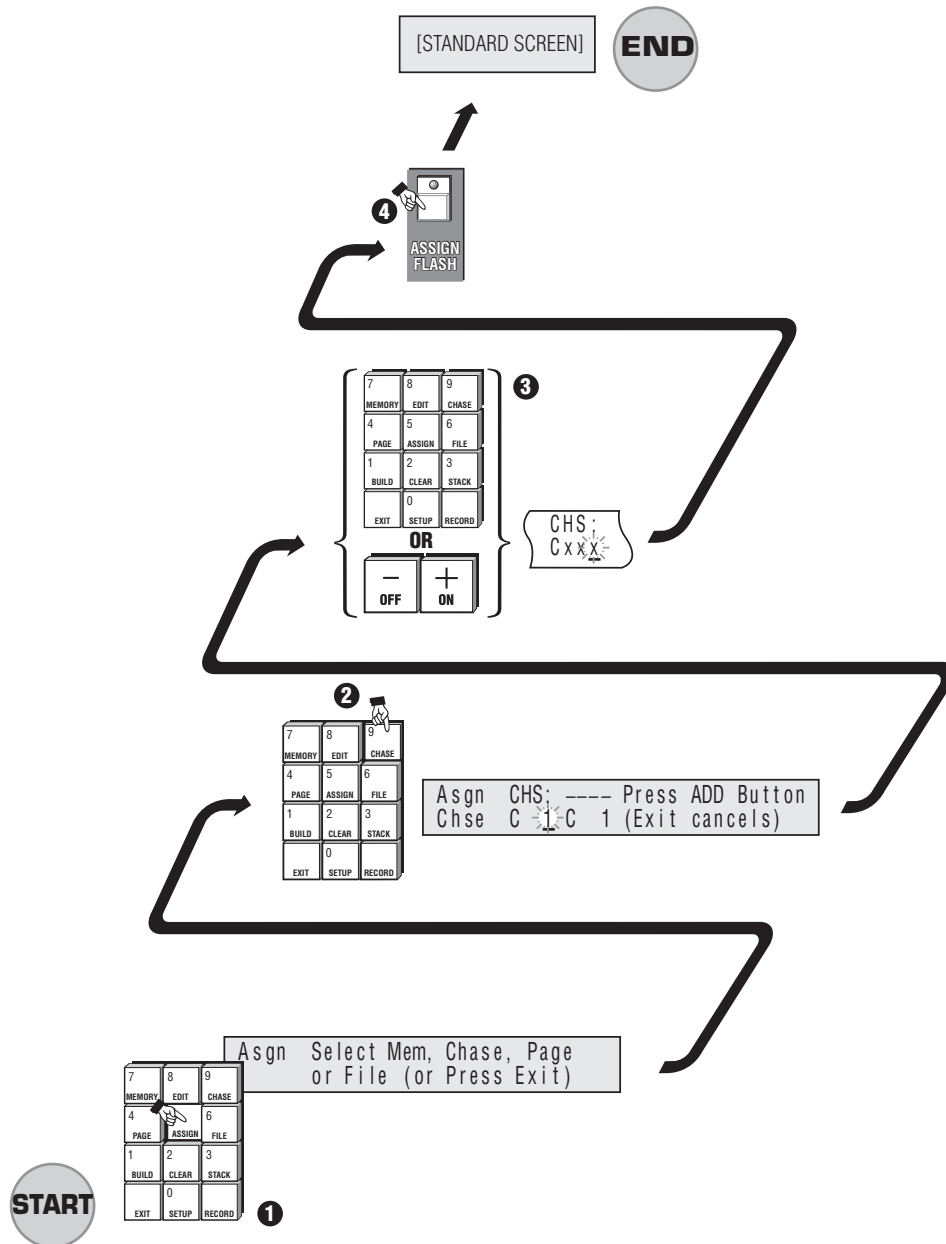

▲ 8I Assign the Chase (Method 2)

### 8.90 Editing a Chase

A Chase can be edited to change the levels of channels or groups of channels. Editing can be carried out 'blind', that is, without the changes being seen on stage, or 'live'. An edit will be Live if that Chase is currently being outputted to the Stage (by one of the Assign Masters).

There **two** way to make changes to the channel intensities:

#### 8.91 METHOD 1: Using the Menu

 **Diagram 8J**

- 1 Press the Edit button.
- 2 Press the Chase button, then use the + (On)/- (Off) button or keypad to enter the Chase number (0 - 999) to be edited.
- 3 Move the cursor to the ST (step) field. Use the + (On)/- (Off) button or keypad to enter the step number.
- 4 Move the cursor to the CH# (channel) field. Use the + (On)/- (Off) button or keypad to enter the new channel number.
- 5 Move the cursor to the TO# field. Use the + (On)/- (Off) button or keypad to enter the new number for the range of channel.
- 6 Move the cursor to the AT (value) field. Use the + (On)/- (Off) button or keypad to enter the new level values.
  
- 7 Press the Record button. The LCD will display the percentage of available Memory space that has been used and that which remains, and return to the standard screen after the button is released.

**Example:**

*In the menu illustrated in diagram 8J, channels 10 through to 15 have been set to 50%.*

- Labelling a Chase as an option (see [Section 8.20](#)).
- Deleting a Step as an option (see [Section 8.100](#)).
- Adding a Step as an option (see [Section 8.110](#)).

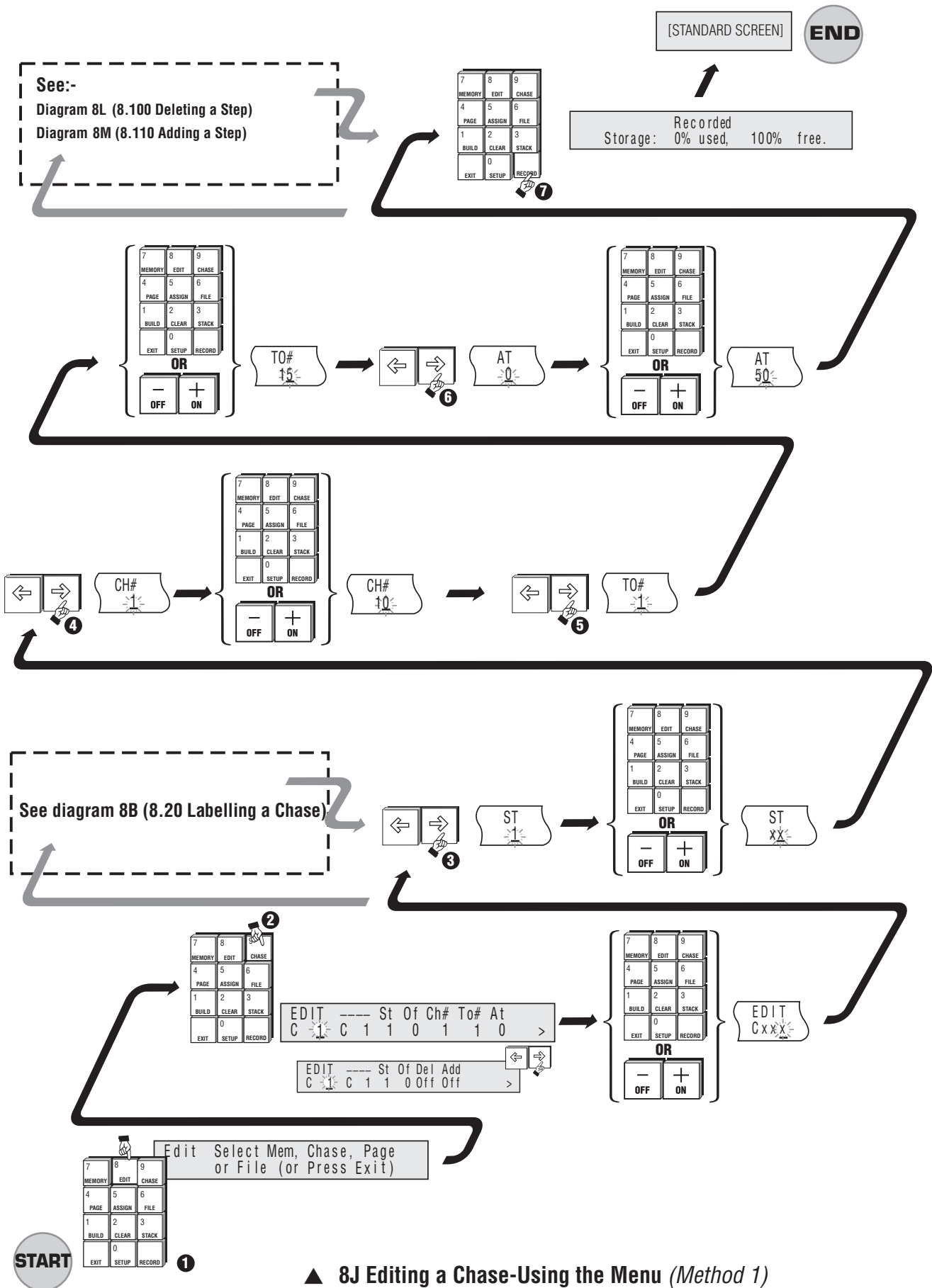

▲ 8J Editing a Chase-Using the Menu (Method 1)

### 8.92 METHOD 2: Using Assign Flash Buttons

 **Diagram 8K**

- 1 Press the Edit button.
- 2 Press the Flash button beneath the Assign fader controlling the item to be edited.
- 3 Use the Preset 1 (top preset) faders to set new levels for the channels you want to change. To edit a channel this way the fader first has to be moved to match the existing level of the channel and then moved to the new level. The simplest way to do this is to move the fader from zero to full and then to the new level.

**TIP:** Finding the Step to edit

If you want to edit a particular Step of the Chase but are not sure of the Step number there is an easy solution. First bring the Chase up on one of the Assign Masters, then use the rotary speed control to slow the chase right down until it stops. Now use the Assign Flash button to single step the Chase to the Step you want. Finally, press the Edit button followed by the Chase Flash button and the edit Chase menu will open with the Step you want to edit already selected.

**NOTE:** As each channel or group of channels is adjusted using either edit method, the changes are stored temporarily so there is no need to press Record to save each individual change.

- 4 Press the Record button. The LCD will display the percentage of available Memory space that has been used and that which remains, and return to the standard screen after the button is released.

**NOTE:** Whenever the EDIT CHASE menu is opened the Preset faders are disabled from outputting to the stage. However, they can be used to set levels for the item being edited.

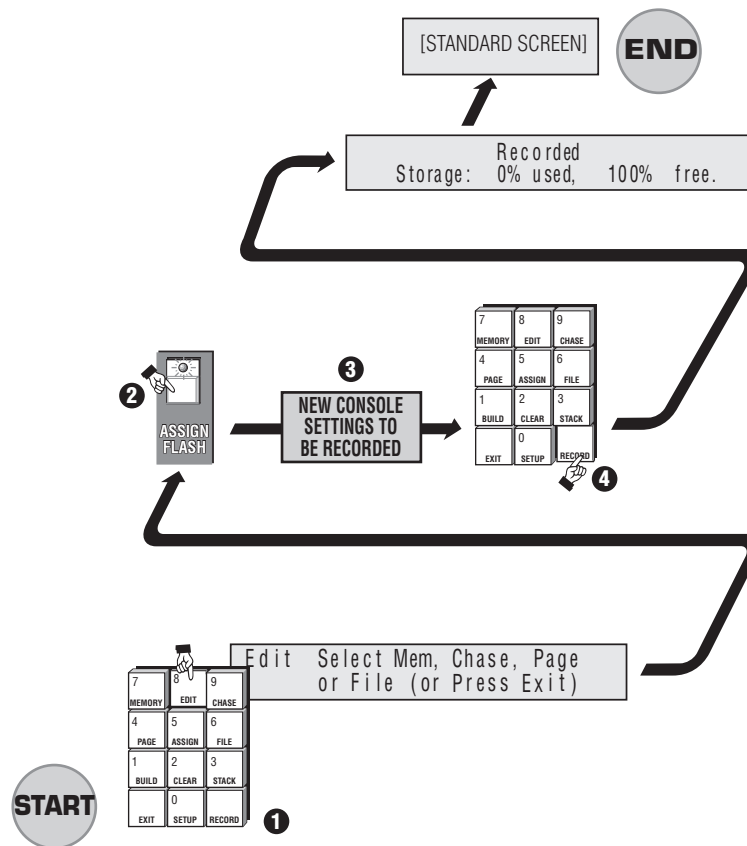

▲ 8K Editing a Chase-Using Assign Flash Buttons (Method 2)

## 8.100 Deleting a Step



To delete a Step use the following procedure:

1. Set the ST (Step) field to the Step number that you wish to remove.
2. Move the cursor to the DEL field.
3. Press the + (On) button.

**NOTE:** The Delete and Add fields are not shown when the Edit Chase menu is opened. Move the cursor to the More field (at the right hand end of the menu) to reveal these fields.

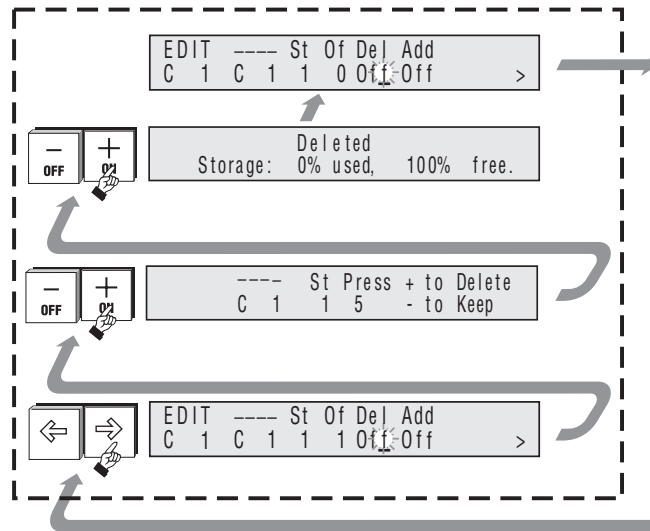

▲ 8L Deleting a Step

### 8.110 Adding a Step

 **Diagram 8M + 8J**

To add a Step use the following procedure:

1. Set the ST (Step) field to the Step number that you wish to add.
2. Move the cursor to the ADD field.
3. Press the + (On) button.

**NOTE:** When Step is added it pushes all the old Step which had an equal or higher number one number higher.

For example, when adding a new first Step set ST to 1. The old Step1 will become Step2 and so on.

Adding the Step does NOT record any levels. After adding the Step either use the faders or the CH# and AT fields to set the levels and press Record button.

### 8.120 Recording Changes Made in Edit

To save the changes made using Edit press the Record button. It is not necessary to press the Record button after each channel (or group of channels) is set to a new level.

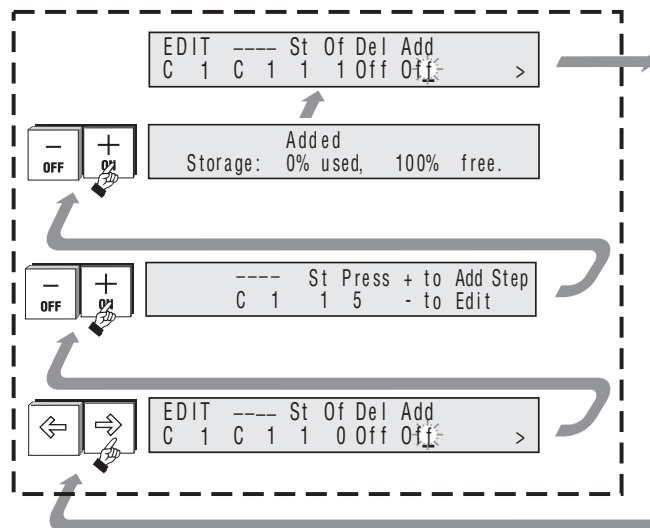

▲ 8M Adding a Step

## **Managing Memories & Chases**

---

# **Managing Memories & Chases**

### 9.00 Pages

If you have been using the Record and Point method you will soon have recorded Memories and Chases on all the Assign faders. To make a new set of Memories and Chases available you will need to change to a new Page.

Pages provide a familiar method of grouping Memories (and Chases) into sets that are used together. It is common to have a Page for each song that a band performs.

The Event provides 99 Pages but memory limitations prevent every Memory and Chase in every Page being used.

#### 9.10 Page Make-Up

On an Event Plus a Page normally consists of 20 Memories and one Chase. Note that the Assign Master faders 23 and 24 (Event Plus only) are not normally included in a Page. They are set aside for fixed Memories or to control a Stack ( to alter the make-up of a Page see [Section 15.00](#)).

#### 9.20 Loading a New Page

 **Diagram 9A**

- 1 Press the Page button to open the Page menu.
- 2 Enter a new Page number.

**TIP:** Type the Page number using two digits i.e. 02. The cursor automatically moves to the load field after the Page number is entered.

- 3 Use the arrow keys to move the cursor to the LOAD field.
- 4 Press the + (On) button. The menu closes and the new Page is loaded.

**NOTE:** If Freeze is on, any Assign faders that were above zero% when the Page was changed will continue to control the old Page Memory until the faders are returned to zero at which time they will join the new Page. Any 'frozen' item's label will flash between its label and number to make it easy to identify.

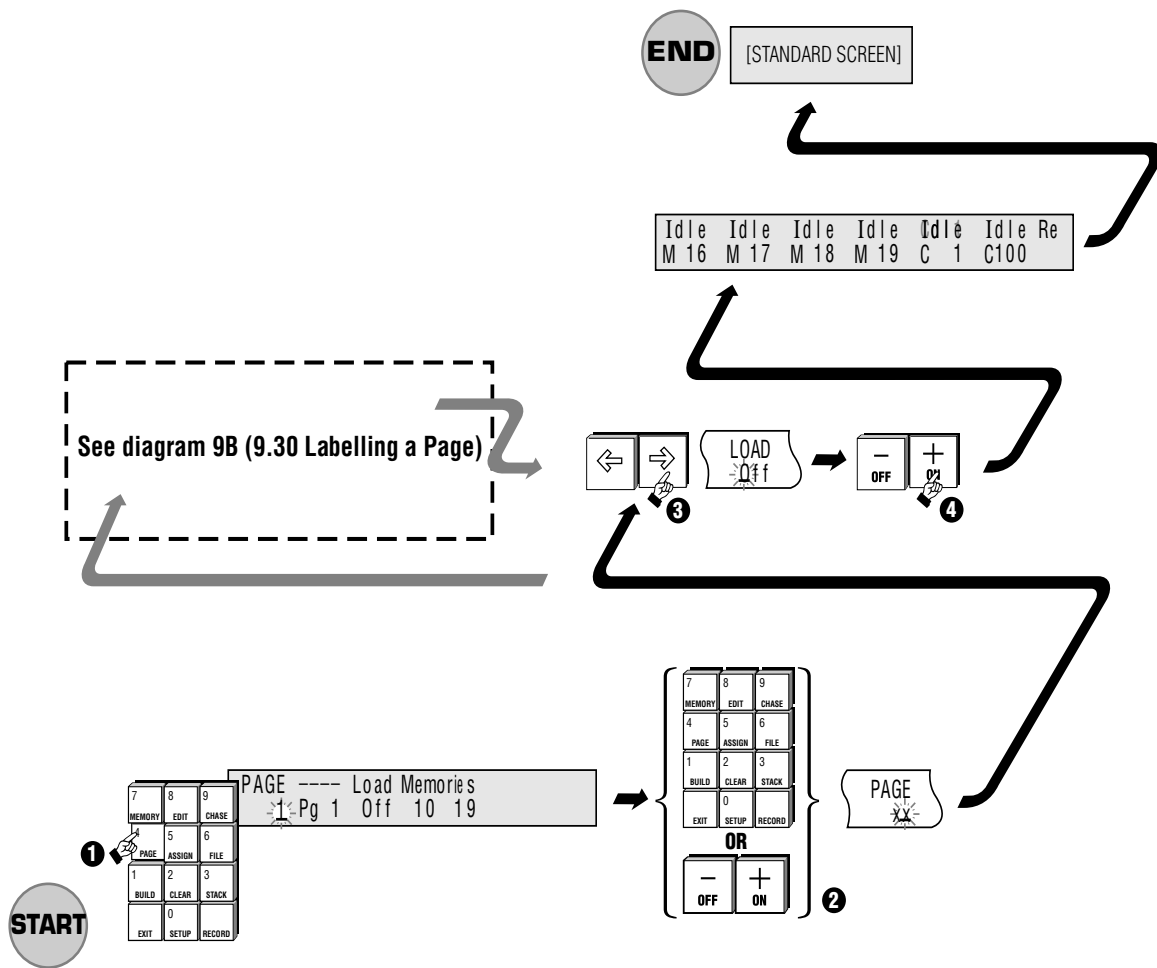

▲ 9A Loading a New Page

### 9.30 Freeze

 Diagram 9B

To turn Freeze on or off:

- ❶ Press the Setup button to open the Setup menu.
- ❷ Move the cursor to the PREF (Preferences) field.
- ❸ Press the + (On) button to open the Set Preferences menu.
- ❹ Move the cursor to the FREEZE field.
- ❺ Press the + (On) button to turn Freeze On. Press the – (Off) button to turn Freeze Off.
- ❻ Press Exit to close this menu (press Exit twice to return to the standard screen).

**NOTE:** If Freeze is on, the output from any Assign Master fader which is above zero will NOT change when a new Page or File is loaded. When an Assign Master is 'frozen' its display will flash between its label and its number, making it easier to determine which faders are not on the current page. When a 'frozen' Assign Master is faded to zero level it will join the current page and may be used to output its current page memory. Its display will also change to indicate the current contents.

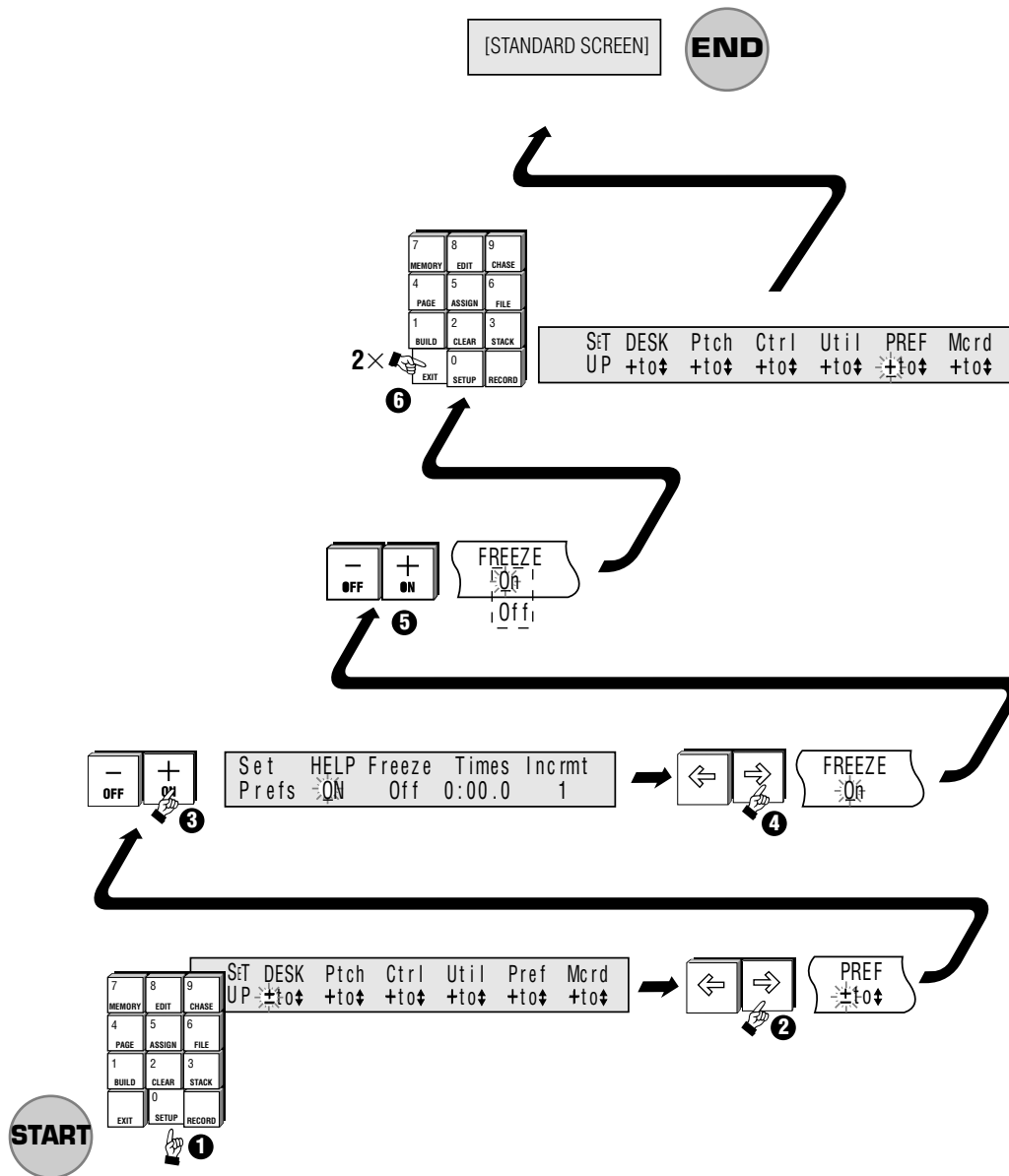

▲ 9B Freeze

## 9.40 Labelling a Page



Pages can be labelled to allow easy identification of their contents. To Label a Page:

1. Move the cursor to the Label field (to the right of the Pages number field).
2. Type a Label of up to eight characters using the Flash buttons.
3. Press the Exit button if no more Pages are to be labelled.

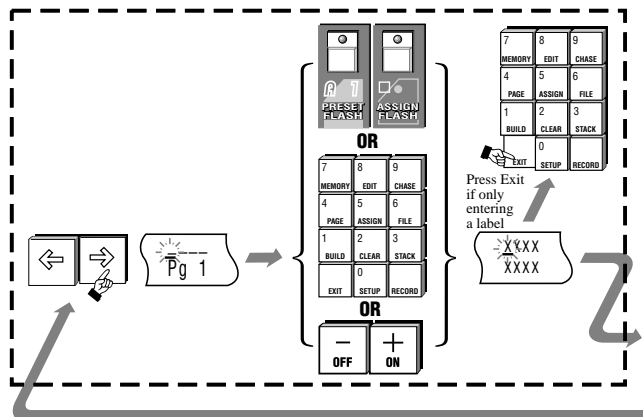

▲ 9C Labelling a Page

## 10.00 Assign

If you have been recording using the menu system, you probably have recorded a list of Memory and Chase numbers but they may not be on the Assign Masters. They might not even be in any kind of numeric order. To put them onto the Assign Masters you will need to use the Event's Assign & File menus.

Assigning is very easy and involves the following steps:

 **Diagram 10A**

1. Use the Assign menu to select the Memory, Chase or start of a Stack.
2. Press the Flash button below the Assign fader you want to control that item.

**NOTE:** Only recorded Memories/Chases/Stacks can be assigned to an Assign fader. If the selected item has not been recorded the console will give the option to record the Memory/Chase/Stack or Exit (see screen display diagram on the left side).

Entry does not exist.  
REC to create or EXIT

▲ 10A menu screen

### 10.10 Assign Memory

 **Diagram 10B**

- 1 Press the Assign button.
- 2 Press the Memory button to open the Assign Memory menu.
- 3 Use the + (On)/– (Off) button or keypad to enter a Memory number.
- 4 Press the Flash button beneath the Assign fader to be used to control this Memory.

Once the flash button has been pressed, the Assign menu is closed and you will see the Assigned Memory has replaced whatever was previously controlled by the Assign Master.

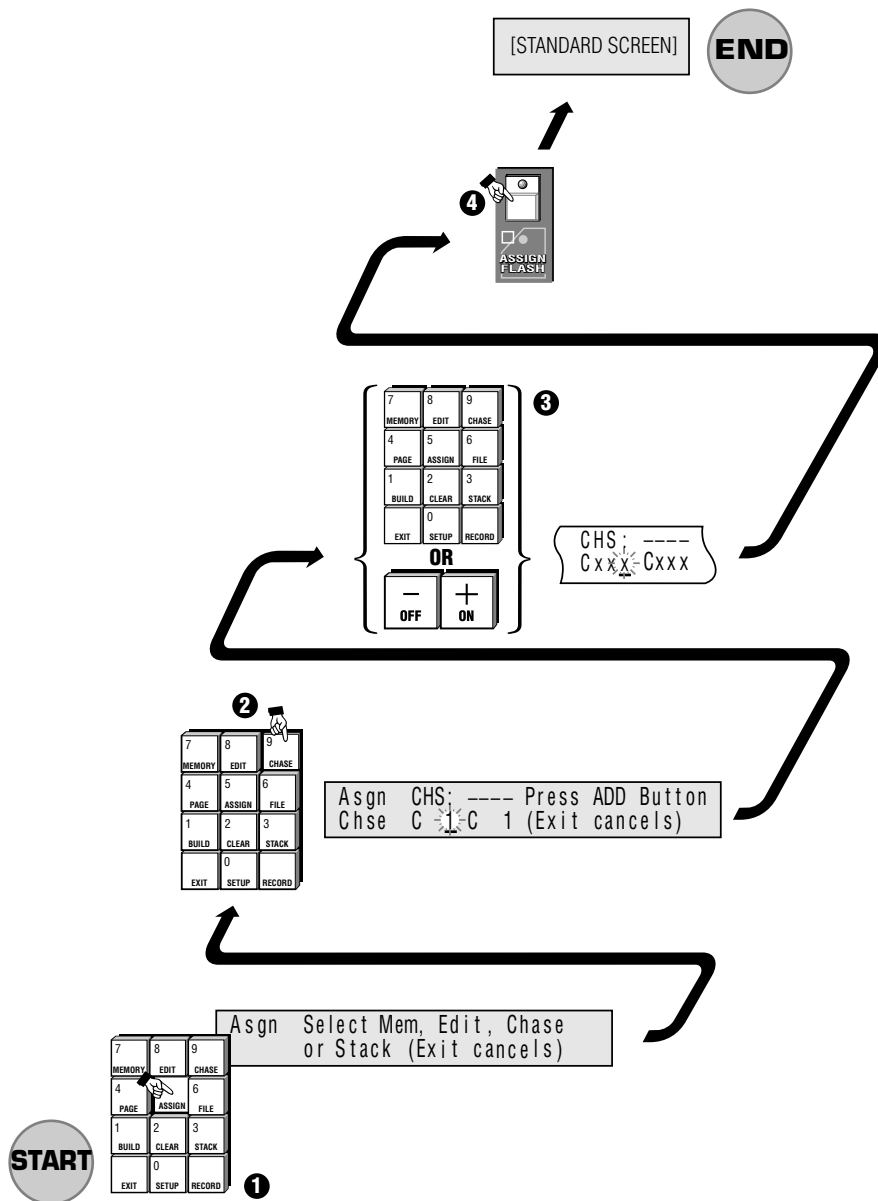

▲ 10B Assign Memory

### 10.20 Assign Chase

 **Diagram 10C**

- 1 Press the Assign button.
- 2 Press the Chase button to open the Assign Chase menu.
- 3 Use the + (On)/– (Off) button or keypad to enter a Chase number.
- 4 Press the Flash button beneath the Assign fader to be used to control this Chase.

Once the Flash button has been pressed, the Assign menu is closed and you will see the Assigned Chase has replaced whatever was previously controlled by the Assign Master.

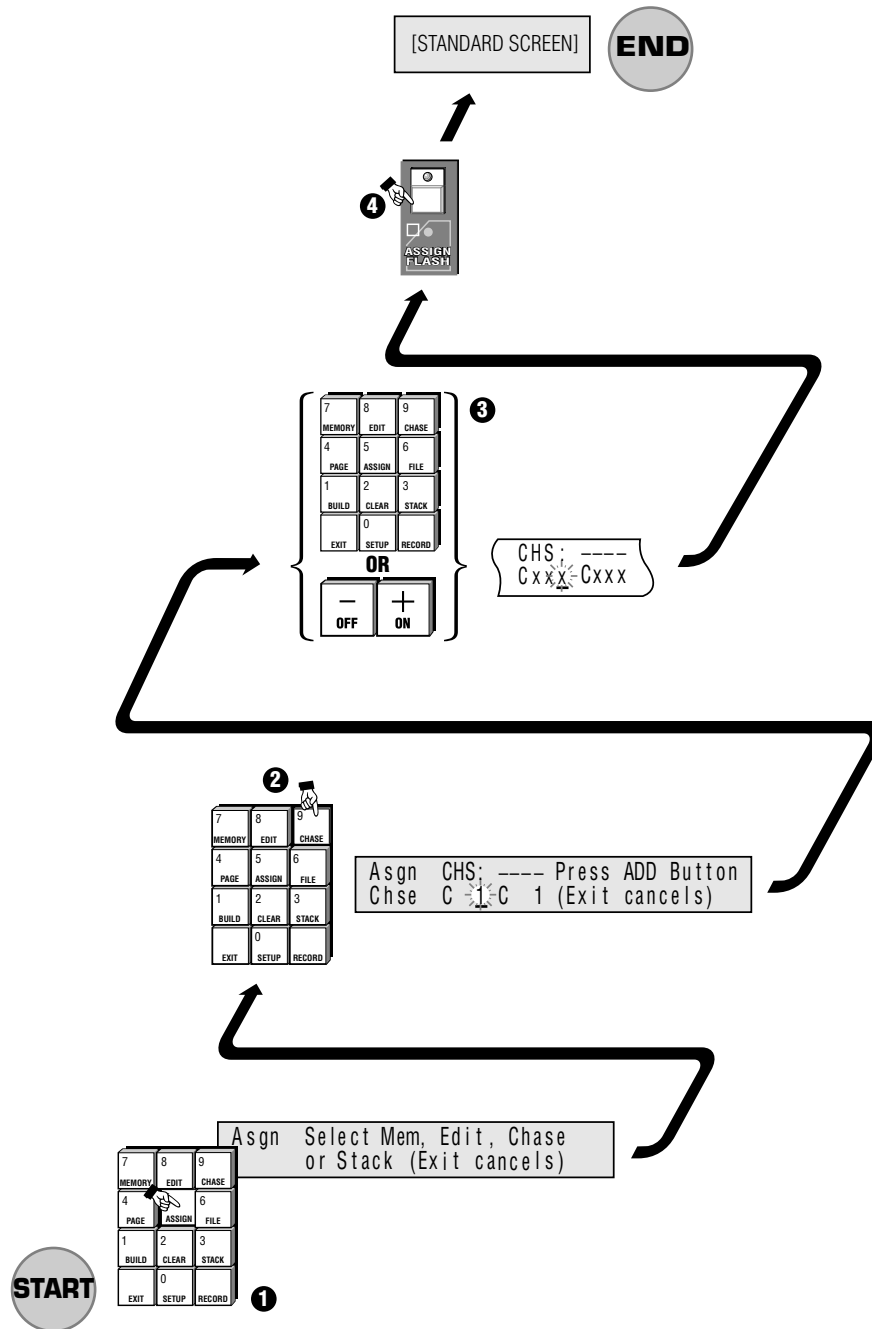

▲ 10C Assign Chase

### 10.30 Assign Stack

 **Diagram 10D**

When a Stack is assigned it uses two Assign faders. The possible fader pairs are: 1&2, 3&4 ..... 23&24.

The left hand fader controls the Infade rate while the right hand fader controls the Outfade rate.

The Flash buttons beneath these faders become GO & BACK buttons.

The LED below the Flash buttons illuminates.

- ❶ Press the Assign button.
- ❷ Press the Stack button to open the Assign Stack menu.
- ❸ Enter the first Memory / Chase number of the Stack.

**NOTE:** This does not have to be the lowest number in the Stack, just the first number you want to use.

- ❹ Press the Flash button beneath the Assign fader to be used to control this Stack.

**NOTE:** Two faders are required, and as such the console automatically sets the adjacent fader.

Once the Flash button has been pressed, the Assign menu is closed and you will see the Assigned Stack has replaced whatever was previously controlled by the Assign Masters.

### 10.40 Special Feature - Assign Edit

If you are used to working with theatrical consoles you may want to record Memories using the menu system to enter Channel - Thru - At values. Event allows this but unless the Memory is already recorded you will not be able to put the memory on an Assign fader and thus be able to see what you are doing.

To get around this problem it is possible to assign the edit output to a fader:

- Press the Assign button followed by the Edit button.
- Press the Flash button beneath the Assign Fader to be used to control the Edit output

Once the Flash button has been pressed, the Assign menu is closed and you will see the Edit output has replaced whatever was previously controlled by the Assign Master.

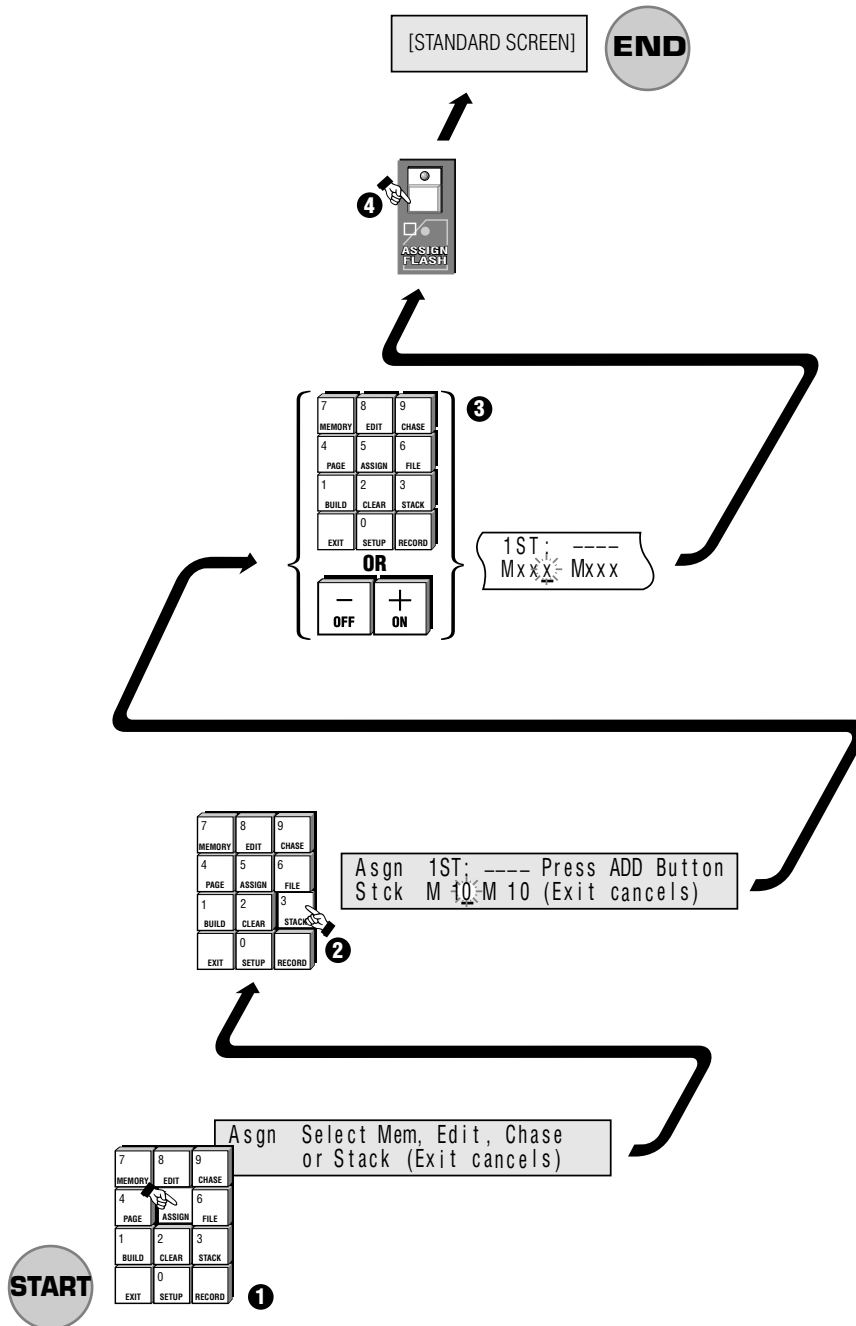

▲ 10D Assign Stack

### 11.00 Files

The previous section described how to assign Memories, Chases and Stacks to the Assign faders. However, assigning items one at a time is slow and after you have set up the faders for a particular song or part of the show you will want to save those settings for easy recall later.

Files are just like Pages except that, while the makeup of a Page is factory set, a File can contain any combination of Memories, Chases and Stacks.

The steps involved in saving and loading Files are described below.

#### 11.10 Saving a File

 **Diagram 11A + 11C**

Ensure that the Assign Masters are loaded with Memories, Chases and Stacks as you require.

- 1 Press the File button.
- 2 Use the keypad or + (On)/– (Off) buttons to enter a File number (0 - 25).
- 3 Use the arrow buttons to move the cursor to the SAVE field.
- 4 Press the ON (+) button to save the file.

#### 11.20 Loading a File

 **Diagram 11B**

- 1 Press the File button.
- 2 Use the keypad or ON (+)/OFF (-) buttons to enter a File number (0 - 25).
- 3 Use the arrow buttons to move the cursor to the LOAD field.
- 4 Press the + (On) button.

The Assign Masters are loaded with the Memories, Chases and Stacks that were previously saved in the File.

**TIP:** If Freeze is on, any Assign faders that were above zero% when the File was changed will continue to control the old Memory / Chase until the faders are returned to zero, at which time they will join the new File.

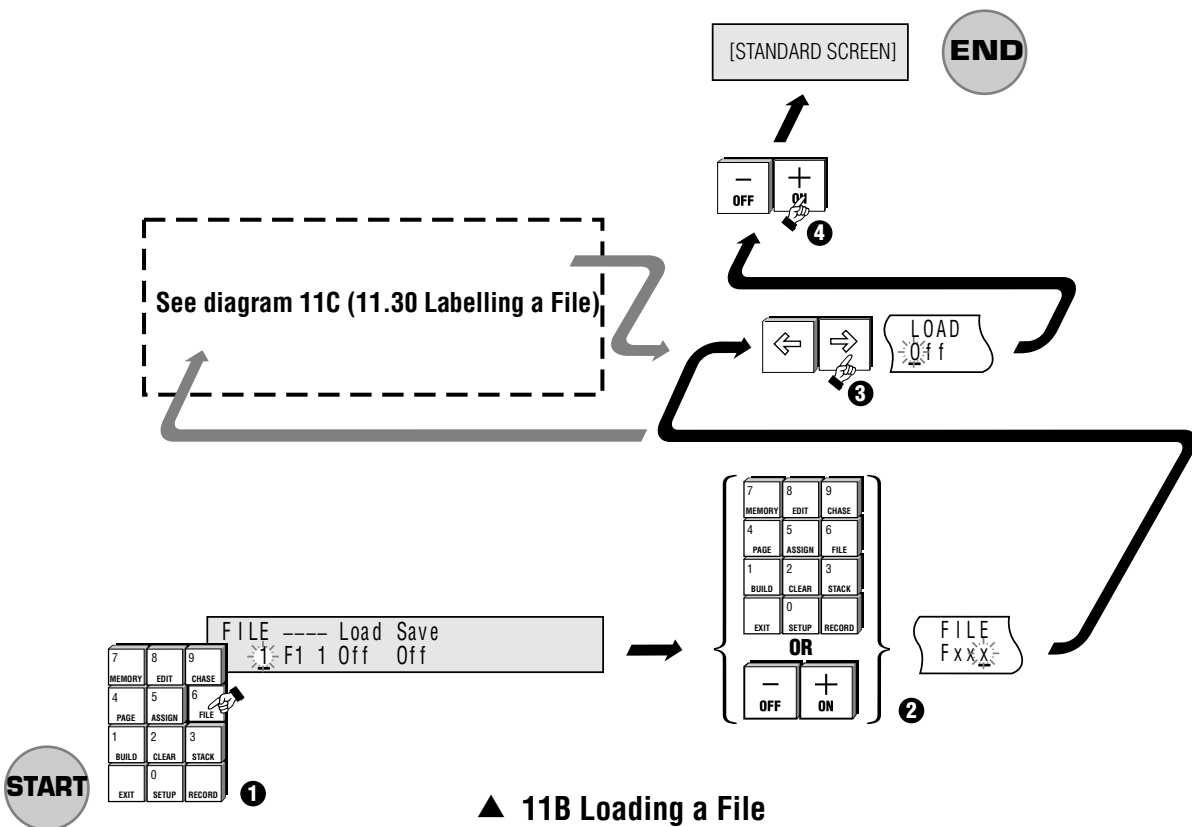
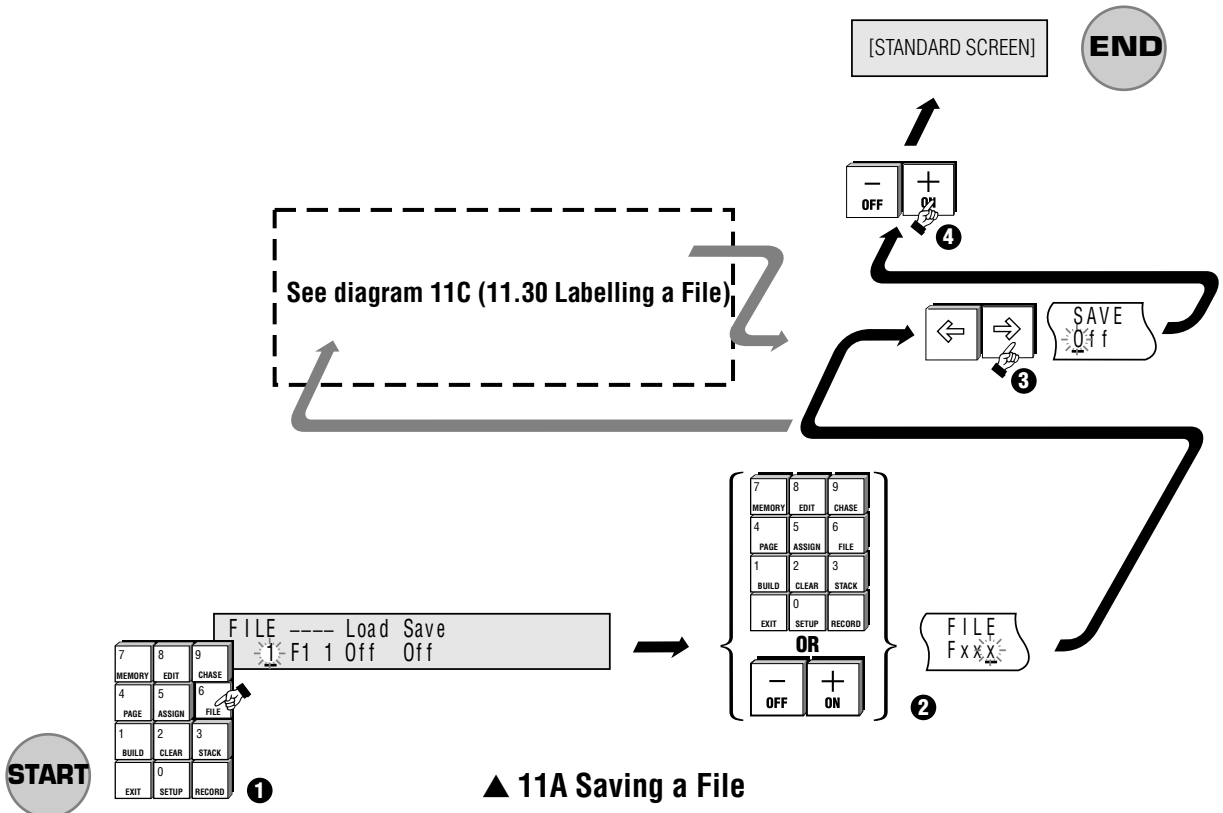

## 11.30 Labelling a File

 **Diagram 11C**

Files can be labelled to allow easy identification of their contents. To Label a File:

1. Move the cursor to the Label field (to the right of the Files number field).
2. Type a label of up to eight characters using the Flash buttons.
3. Press the Exit button if no more Files are to be labelled.

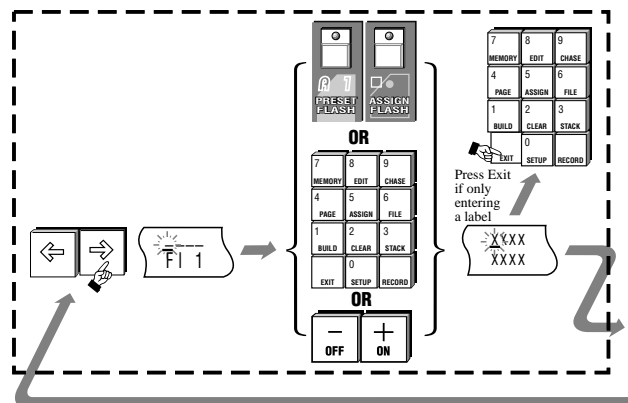

▲ 11C Labelling a File

## 12.00 Stacks

Section 10 explained how to control Memories and Chases using the Assign faders. Many shows are run this way, with the operator manually fading Memories and Chases in and out to suit whatever is happening on stage.

An alternate approach, commonly used in the theatre, is to automate this process by setting infade and outfade times for each Memory and Chase and then simply pressing a Go button which fades in a new lighting 'look', and at the same time fades out whatever lights were on previously.

The Event offers this theatrical method through the use of Stacks. The name comes from the idea of a Stack of Memories that can be played back one after another.

Sometimes operators plan to use Stacks and record each of the lighting looks they want to use in order. However, with the Event it is not necessary to do this and Memories and Chases can be linked together in any order. However any Memory or Chase can only be used once in a Stack.

Usually the operator instigates the start of each new lighting look by pressing the Go button. However, sometimes it is useful to have several Memories follow each other at a preset time, fading in and out automatically. Some industrial shows which run to an exact schedule are fully programmed this way. The Event also includes this feature.

### 12.10 Control fields

Both the Memory and the Chase menus include fields which control how they behave when used in Stacks:

#### 12.11 NEXT fields

 **Diagram 12A**

This field sets which item follows the Memory or Chase. The field is factory set in numeric order, i.e. The NEXT field in Memory 10 is set to Memory 11.

#### 12.12 INFADE / OUTFDE (Outfade) fields

 **Diagram 12B, 12C**

The INFADE field sets the time the Memory or Chase will take to fade from 0% to 100%, i.e. if set to 0:10.5, it will take this Memory or Chase 10.5 seconds to fade up to full output.

The OUTFDE (Outfade) field sets the time the Memory or Chase will take to fade from 100% to 0%, i.e. if set to 0:08.2, it will take this Memory or Chase 8.2 seconds to fade out completely.

Mem:	----	NEXT	Delay
M 10	M 11		0:00.0

▲ **12A** Next field

Mem:	----	INFADE	Outfde
M 10	M 10	0:00.0	0:00.0 More

▲ **12B** Infade field

Mem:	----	Infade	OUTFDE
M 10	M 10	0:00.0	0:00.0 More

▲ **12C** Outfade field

## Managing Memories & Chases

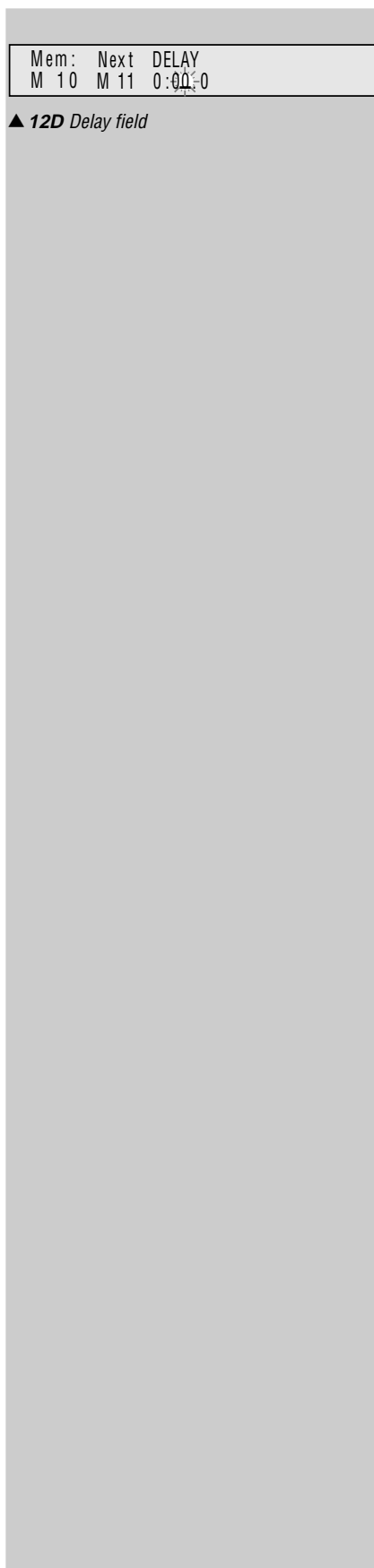

### 12.13 Delay field

#### Diagram 12D

This field sets the time between the start of this Memory or Chase and the start of the Infade of the Memory or Chase set in the NEXT field, i.e. if set to 0:10.5 the next Memory or Chase will begin to fade in 10.5 seconds after this Memory started to fade in.

**NOTE:** In the Memory menu the Infade and Outfade fields can be seen when the menu is opened and the NEXT field is revealed by moving the cursor to the extreme right hand side of the menu.

In the Chase menu the Infade, Outfade and NEXT fields are revealed by moving the cursor to the extreme right hand side of the menu (to where it shows MORE).

### 12.20 Changing the NEXT Field

The NEXT field is used to determine the playback order of Memories and Chases in a crossfade Stack. This facility can also be used to insert a Chase or Memory into a Stack sequence.

### 12.21 Changing the NEXT Field - Memory

#### Diagram 12E

- 1 Press the Memory button.
- 2 Enter the required Memory (0 - 999) using the numeric keypad or alternatively use the + (On)/- (Off) buttons to change the displayed Memory number.
- 3 Move the cursor to the MORE field and keep moving the cursor to the NEXT field after the MORE window is opened.
- 4 Enter the number of the Memory which is to follow this Memory.
- 5 Press the Exit button, if no more Memories are to be set.

**NOTE:** Do NOT press the Record button if only entering or changing the NEXT field.

**TIP:** If in the Memory menu you want to change the setting from a Memory number to a Chase, use the left arrow button to move the cursor over the M and then press the + (On) button to change the M to a C. (this can also be achieved by pressing the Flash button marked C).



### 12.22 Changing the NEXT Field - Chase

 **Diagram 12F**

- ❶ Press the Chase button.
- ❷ Enter the required Chase number (0 - 999) using the numeric keypad or alternatively use the + (On)/- (Off) buttons to change the displayed Chase number.
- ❸ Move the cursor to the MORE field and keep moving the cursor to the NEXT field after the MORE window of Chase opens.
- ❹ Enter the number of the Chase which is to follow this Chase.
- ❺ Press the Exit button if no more Chases are to be set.

**NOTE:** Do NOT press the Record button if only entering or changing the NEXT field.

**TIP:** If in the Chase menu you want to change the setting from a Chase number to a Memory, use the left arrow button to move the cursor over the C and then press the + (On) button to change the C to a M, (this can also be achieved by pressing the flash button marked M).

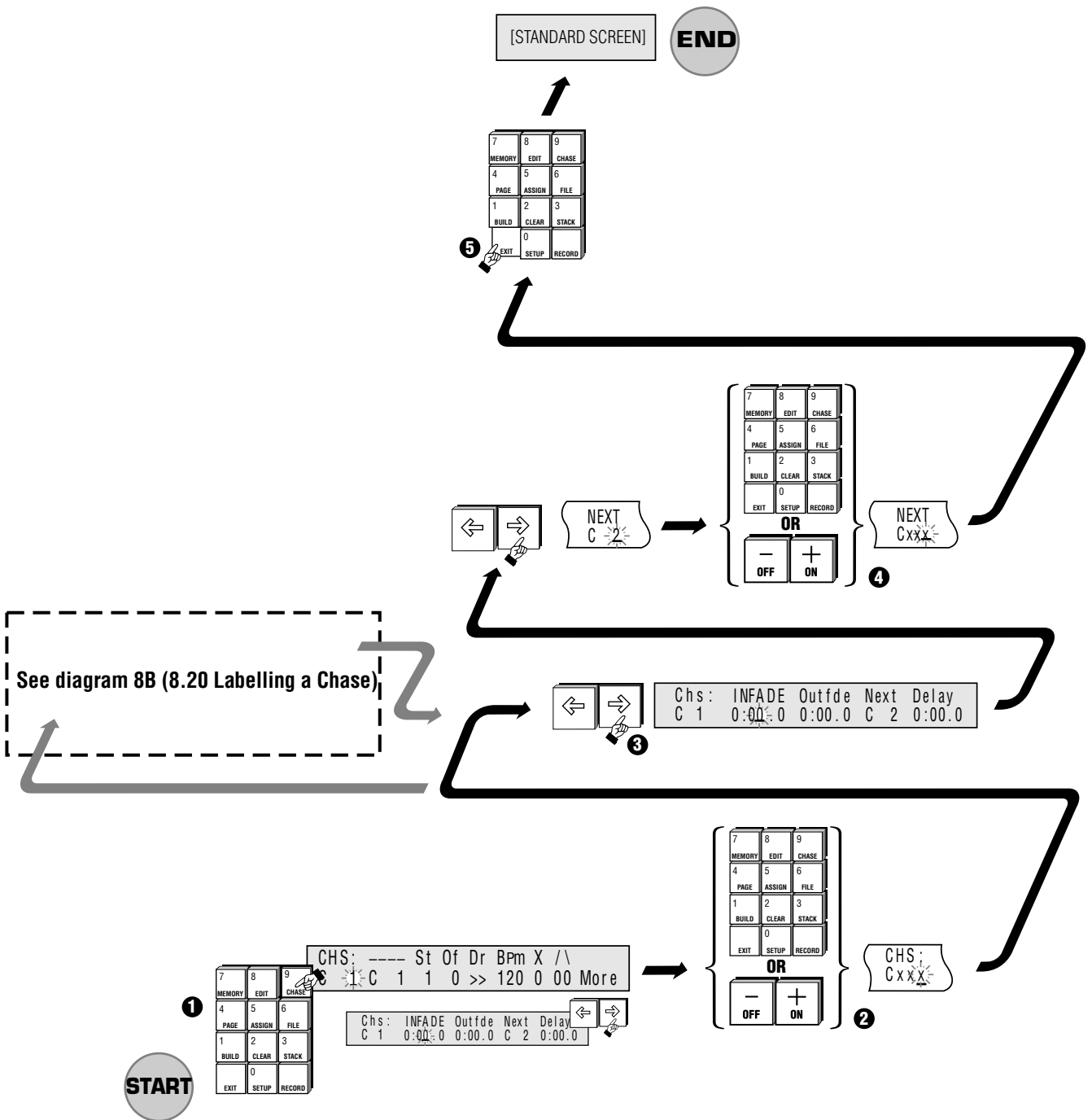

▲ 12F Changing the NEXT Field - Chase

### 12.30 Infade/Outfade - Adding Fade Times

Fade times can be added to Memories and Chases so that they can then be played back as part of a Stack with automatic timed crossfades.

#### 12.31 Adding Fade Times to a Memory

 **Diagram 12G**

- 1 Press the Memory button.
- 2 Enter the required Memory number (0 - 999) using the numeric keypad or alternatively use the + (On)/- (Off) button to change the displayed number.
- 3 Use the arrow button to move the cursor to the INFADDE field.
- 4 Enter an Infade time of up to 99 minutes 59 seconds using the numeric keypad or alternatively use the + (On)/- (Off) buttons to change the existing value.
- 5 Use the arrow button to move the cursor to the OUTFDE (Outfade) field.
- 6 Enter an Outfade time of up to 99 minutes 59 seconds using the numeric keypad or alternatively use the + (On)/- (Off) buttons to change the existing value.
- 7 Press the Exit button if no more Memories are to be set.

**NOTE:** Do NOT press the Record button if only entering or changing the fade times.

**TIP:** Set a default fade time in Setup:Pref:Time



### 12.32 Adding Fade Times to a Chase

 **Diagram 12H**

- 1 Press the Chase button.
- 2 Enter the required Chase number (0 - 999) using the numeric keypad or alternatively use the + (On)/- (Off) button to change the displayed number.
- 3 Move the cursor to the MORE field, and keep moving the cursor to the INFAD field after the MORE window of Chase opens.
- 4 Enter an Infade time of up to 99 minutes 59 seconds using the numeric keypad or alternatively use the + (On)/- (Off) button to change the existing value.
- 5 Use the arrow buttons to move the cursor to the OUTFDE (Outfade) field.
- 6 Enter an Outfade time of up to 99 minutes 59 seconds using the numeric keypad or alternatively use the + (On)/- (Off) button to change the existing value.
- 7 Press the Exit button if no more Chases are to be set.

**NOTE:** Do NOT press the Record button if only entering or changing the fade times.

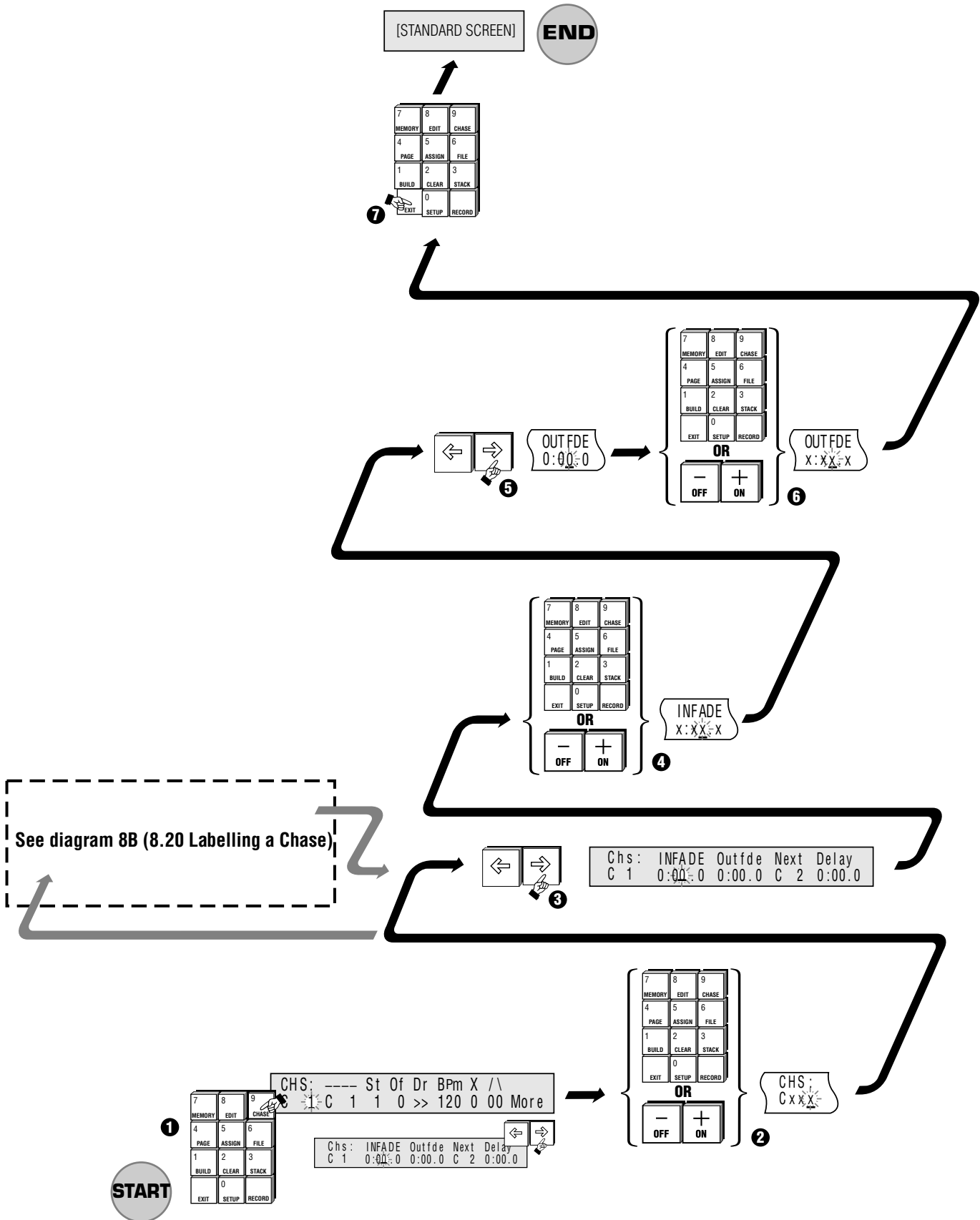

▲ 12H Adding Fade Times to a Chase

### 12.40 Adding Delay Time

This function can be used to automate industrial shows by setting delay times for all Memories used in the show.

Complex chase patterns can be created by setting delay times and using the Next field to loop Memories (and Chases) back on themselves

#### 12.41 Adding Delay Time to a Memory

 **Diagram 12I**

- 1 Press the Memory button.
- 2 Enter the required Memory number (0-999) using the numeric keypad or alternatively use the + (On)/- (Off) button to change the displayed Memory number.
- 3 Move the cursor to the MORE field, and keep moving the cursor to the DELAY field after the MORE window of Chase opens.
- 4 Enter a Delay time of up to 99 minutes 59 seconds using the numeric keypad or alternatively use the + (On)/- (Off) button to change the existing value.
- 5 Press the Exit button to close the window and return to the standard window.

(To use the Assign Masters to control a Stack see Playback [Section 13.00](#))

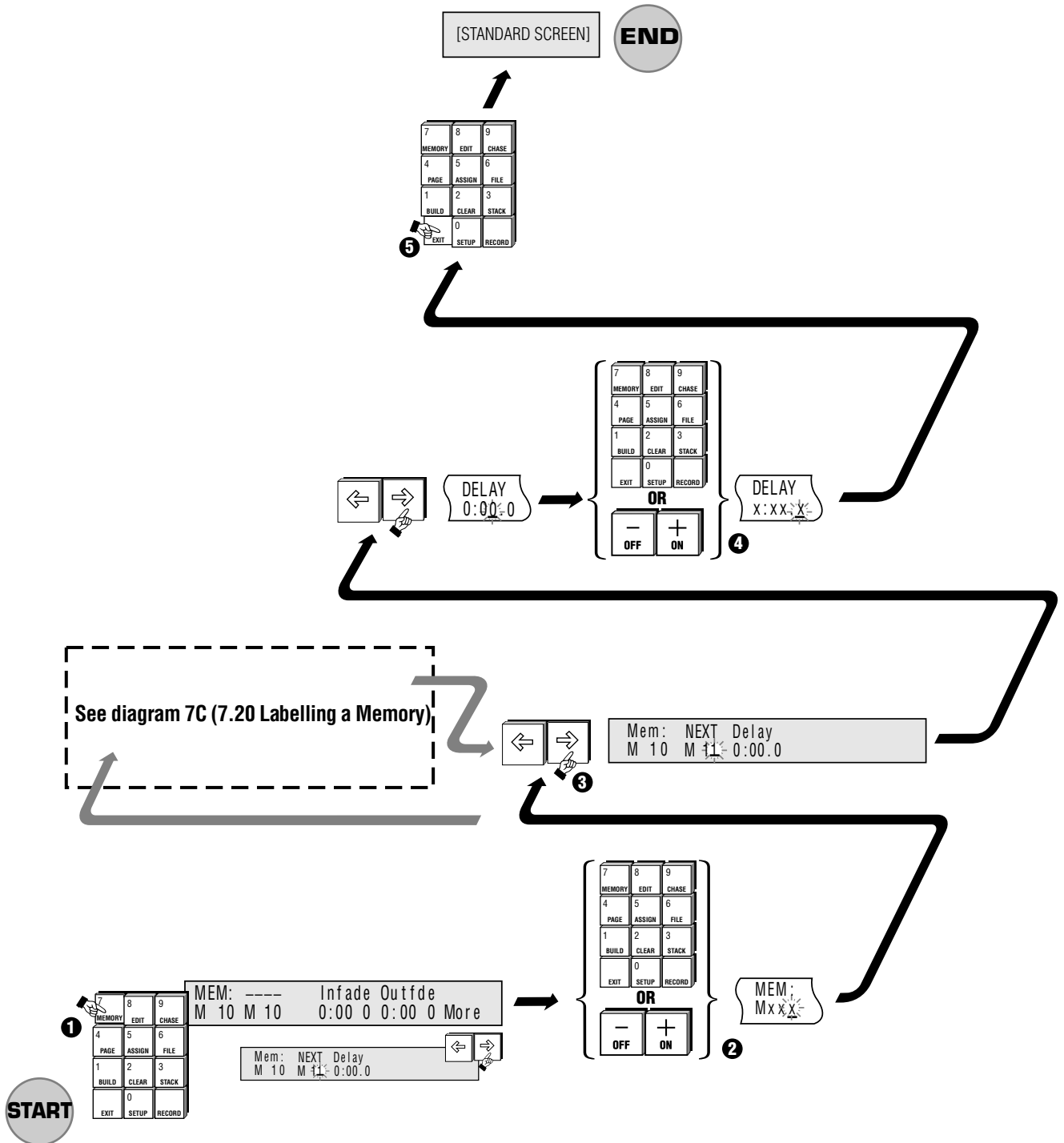

▲ 121 Adding Delay Time to a Memory

### 12.42 Adding Delay Time to a Chase

 **Diagram 12J**

- ❶ Press the Chase button.
- ❷ Enter the required Chase number (0-999) using the numeric keypad or alternatively use the + (On)/- (Off) button to change the displayed Memory number.
- ❸ Move the cursor to the MORE field, and keep moving the cursor to the DELAY field after the MORE window of Chase opens.
- ❹ Enter a Delay time of up to 99 minutes 59 seconds using the numeric keypad or alternatively use the + (On)/- (Off) button to change the existing value.
- ❺ Press the Exit button to close the window and return to the standard window.

(To use the Assign Masters to control a Stack see [Section 13.00](#))

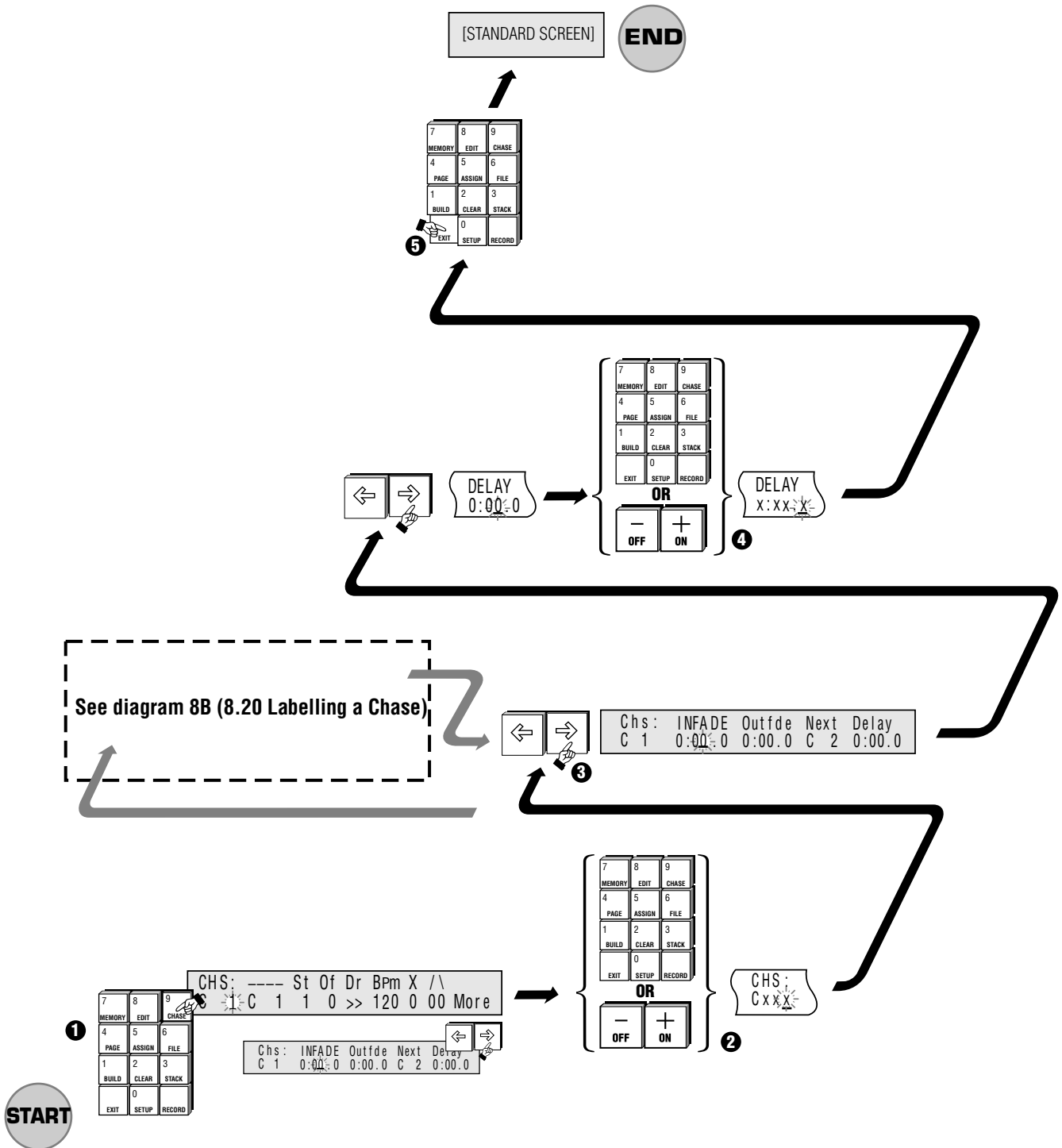

▲ 12J Adding Delay Time to a Chase

## **Control Functions - Playback**

---

# **Control Functions - Playback**

# 13.00 Playback

The Event offers a combination of manual and automated playback controls which are both powerful and easy to use:

- Two banks of Presets of channel faders provide direct control of each channel.
- The Assign Masters control individual Memories and Chases.
- A pair of Assign faders can control a Stack containing any number of Memories and Chases.
- Flash buttons on each channel and Assign Master.
- The Hold/Smaster fader can be used for any one of four functions: Assign Master, Snapshot, Assign Submaster or manual Crossfader.
- Overall controls are provided for: Preset 1 & 2, Flash buttons, DBO, Chase rate and Grand Master.

## 13.10 Controls

### 13.11 Preset Faders

#### Diagram 13A ①

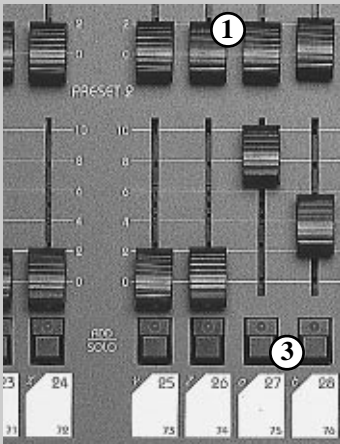

▲ 13A Preset faders / Flash buttons

There are two rows of Presets faders on the Event. The top row of faders is Preset 1 and the bottom row is Preset 2. These faders can be used to smoothly fade a light to the desired level. The output level produced by the preset faders is dependent on the level of the Grand Master and the P1 (or P2) Master fader.

#### Example:

- Bring the Grand Master and P1 Master faders to 10 (100%).
- Move the Channel 1 Preset fader to 100% and you should see the lights connected to that channel fade up to full level.
- Now fade up Channel 2 to 5 (50%) and check that the lights connected to Channel 2 are at about 50% level.
- Finally fade the P1 Master down and up to see how it scales the Channel Preset faders.

### 13.12 Assign Masters

#### Diagram 13B ②

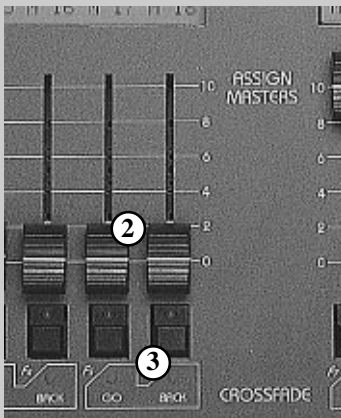

▲ 13B Assign faders / Flash buttons

The Assign Master faders provide a powerful array of features. Underneath each fader is a Flash button with LED and above the fader is a two line, four character LCD window. These faders can be used to:

- \* To control a single Memory
- \* To control a single Chase
- \* To control a Stack made up of Memories and / or Chases

### 13.13 Flash Buttons

#### Diagram 13A, 13B ③

The Flash buttons operate in three ways, depending on the setting of the Add / Solo master switch:

- \* **Add** : The Memory goes to the level set by the Add / Solo Master.



- \* **Solo:** The Memory goes to the level set by the Add / Solo Master and at the same time blacks out the other console controls.
- \* **Latch:** Press once to switch the Memory on at the level set by the Add / Solo Master. Press again to switch the Memory off.

**TIP:** Timed Fades  
 If you have set an Infade time, the Memory will fade in over that time whenever the Flash button is pressed. Likewise, if you have set an Outfade time, the Memory will fade out over that time when the Flash button is released.

### 13.14 LCD Windows

**Diagram 13C**

The windows above the Assign Master faders show the Memory number or name (to add a name at any time use the Memory menu see [Section 7.00](#)).

**TIP:** If you have given a Memory a name and want to know what number it is, hold down the Record button. The LCD will then change to show the number of each item on the display.

### 13.20 Controlling Memories

Once a Memory has been assigned to a fader or loaded as part of a Page or File it is ready for use.

#### 13.21 Assign Masters

**Diagram 13B** 2

The Assign Master fader is used to scale the intensity of the Memory from 0% to 100%.

#### 13.22 LCD Windows

**Diagram 13C**

The Memory number or name, if one is used, will appear in the LCD window above the fader (to add a name at any time use the Memory menu see [Section 7.00](#)).

**TIP:** If you have given a Memory a name and want to know what it is, hold down the Record button. The LCD will then change to show the label of each item on the display.

### 13.30 Controlling Chases

Chases are controlled in much the same way as Memories.

#### 13.31 Assign Masters

**Diagram 13B** 2

The Assign Master fader is used to scale the intensity of the Chase from 0% to 100%.

### 13.32 Flash Buttons

 **Diagram 13A, 13B** 

The Flash buttons operate in three ways, depending on the setting of the Add / Solo master switch:

- \* **Add** : The Chase goes to the level set by the Add / Solo Master
- \* **Solo**: The Chase goes to the level set by the Add / Solo Master and at the same time blacks out the other console controls.
- \* **Latch**: Press once to switch the Chase on at the level set by the Add / Solo Master. Press again to switch the Chase off.

**TIP:** The Flash button can be further configured through the Setup menu to provide either normal operation where the Chase runs as long as the button is held down, or single operation where if the button is pressed, the Chase runs from the first to the last Step and then stops.

### 13.33 To Change the Operation of the Chase Flash Button

1. Press the Setup button to open the Setup Menu.
2. Move the cursor to the CTRL (Controls) field and press the + (On) button to open the Set Control menu.
3. Move the cursor to the CHS field and press the + (On) button to toggle between NORM (Normal) and SNGL (Single).
4. Press Exit to close this menu (press Exit several times to close all menus).

**TIP: Timed Fades**

If you have set an Infade time, the Chase will fade in over that time whenever the Flash button is pressed. Likewise, if you have set an Outfade time, the Chase will fade out over that time when the Flash button is released.

### 13.34 LCD Window

 **Diagram 13C**

The LCD window above the fader shows the Chase number or name if one is provided. (To add a name at any time use the Chase menu see [Section 8.00](#)).

**TIP:** If you have given a Chase a name and want to know what number it is, hold down the Record button. The LCD will then change to show the number of each item on the display.

If a Chase is running the current step is also shown when you hold down the record button.

### 13.40 Controlling Stacks

Stacks require more time and pre-show planning to set up but offer the advantage of dipless crossfading between Memories and Chases. A complete show could be run from one Stack, or a number of Stacks could be used during playback to control specific segments of a show.

The Event allows you to use several Stacks simultaneously.

To control a Stack you have to use two adjacent Assign Masters. To get the Stack onto these Masters you can use **two** different methods. The best method to use will depend on the type of show that you are running, as explained below:

1ST: ----	Faders	Load & Fix
M 10 M 10	11 - 12	Off

▲ 13D Stack menu screen

### 13.41 METHOD 1: Using the Assign Stack Menu

This method is best if you are only using a Stack occasionally or for a specific part of a show (assigning a Stack is explained in [Section 10.30](#)).

### 13.42 METHOD 2: Using the Stack Menu/Assign Faders as Stack Controls

#### Diagram 13D

If you want to have a Stack available all the time it is best to use the Stack menu to dedicate two faders to Stack playback. However, this does not mean that these faders can only playback memories in a specific order. It is possible to change the playback order, skip unwanted items and even take manual control of the memories in the Stack.

Press Stack to open the Stack Menu. The Stack menu contains four fields:

- \* **1st:** The first Memory / Chase  
*The 1st field sets which Memory or Chase will become the first cue.*

**TIP:** If a Memory number is showing and you wish to use a Chase as the first Cue you can type a C (Add / Solo flash button 3) and then a number.

- \* **Label:** The Label field uses both lines of the LCD  
*The label of the Memory or Chase selected as the 1st cue is shown but can not be changed in this menu.*
- \* **Faders:** The Assign Faders  
*The Assign Faders field sets which pair of Assign Masters will be used to control the Stack. Possible settings are 1&2, 3&4, ..... 23&24.*
- \* **Load & Fix:**  
*This field turns the Stack On or Off. When this field is changed to On (or Off), the menu is automatically closed.*

### 13.50 Playback of a Stack

No matter which method you've used to set up a Stack, playback is controlled the same way. But before going any further there are a few features of the Stack system that should be understood:

- \* In a Stack, Memories and Chases follow each other according to the order set in the Next field of the Memory and Chase menus.
- \* If no Next fields have been changed, Memory 10 will be followed by Memory 11 and so on to Memory 999. Memory 999 is followed by Chase 1 and then Chase 2 and so on.
- \* If a Memory or Chase number has not been used it will be ignored and the next recorded item, if any, will be the next Memory.
- \* Since Memories and Chases can be used together in a Stack they are sometimes referred to collectively as Cues.

### 13.51 Stack Controls

#### Diagram 13E ①

When a Stack is turned on, the LEDs underneath the flash buttons turn on. These are marked Go and Back and provide an indication that a Stack is running.

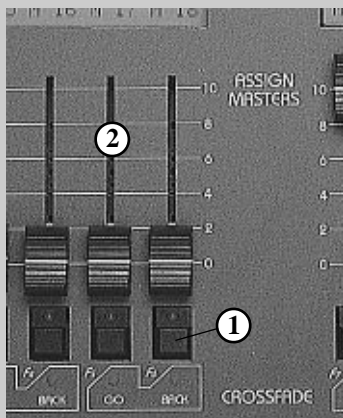

▲ 13E Assign faders / Flash buttons

## Control Functions - Playback

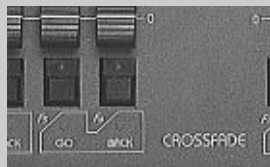

▲ 13F Go/Back Buttons



► 13G Clear button

### 13.52 Assign Master Faders

#### Diagram 13E ②

The Assign Master faders controlling a Stack do two things:

1. During a crossfade they act as fade override controls. The left hand fader controls the Infade rate of the cue fading in and the right hand fader controls the Outfade rate of the cue fading out.
2. When the crossfade is completed the left hand fader becomes a level control scaling the level of the current Memory or Chase.

Normally the faders are left up (at 100%). When they are in this position they do not affect the timing of the crossfade (to take manual control of the crossfade see Section 13.70).

### 13.53 Go / Back Buttons

#### Diagram 13F

The Flash button below the left hand fader is the GO button for a Stack. Pressing the GO button initiates the infade of the next Cue and the outfade of the current (stage) Cue.

The Flash button below the right hand fader is the BACK button for a Stack. Pressing the BACK button returns the current (stage) output to the previous Cue. It is only possible to back up one cue.

### 13.54 LCD Window

#### Diagram 13C

When a Stack is on, the LCD window shows the current (on stage) Cue label above the right hand fader and the next Cue label above the left hand fader. When the stack is first turned on there is no output to stage so the right hand display is blank.

**NOTE:** When a Cue is running the display changes to show the percentage of fade completed and the time, in seconds, left to run.

### 13.60 Clear Output From a Stack

#### Diagram 13G

To clear the output from a Stack:

1. Press the Clear button on the function keypad.
2. Press the Go button of the Stack to be cleared.

Clearing a Stack snaps the current output from the Stack to zero level. However, the Stack is still ON and a new infade can be started by pressing GO.

### 13.70 Taking Manual Control of a Fade

It is not unusual to need to take control of a Cue to allow for changes that occur in a live performance. A performer might be late arriving on stage or skip over some part of the show.

1. The left hand fader controls the infade. To take manual control of an Infade move the fader to match the elapsed fade percentage. The LCD window changes to show MAN: / 20% (or whatever fade percentage has elapsed).

2. The fader can now be moved up or down to control the progress of the infading Cue. If the level is taken to 100% the infade is completed.
3. To take manual control from the beginning of the Cue, pull the fader down to zero before pressing the Go button.
4. The right hand fader (above the Back button) controls the Outfade. To take manual control of an Outfade move the fader to match the elapsed fade percentage. The display changes to show: MAN: / 20% (or whatever fade percentage has elapsed).
5. The fader can now be moved up or down to control the progress of the outfading Cue(s). If the level is taken to 100% the outfade is complete.

**NOTE:** Leaving the Outfade under manual control means that all subsequent memories will come under manual control when the fade percentage reaches the fader setting. Thus if Memory 2 was taken under control after 50% of the fade time had elapsed it would stay on at 50%. If the fader was left at this level the next press of GO would cause Memory 3 to fade to 50% and Memory 2 to fade from 50% to 25% (i.e. 50% of 50%).

### 13.71 Taking Manual Control When a Fade has completed

When the Infade of a new Cue and the Outfade of the old Cue are completed, the fader that normally controls the Outfade time (the right hand fader) switches to control the stage level. The fader can then be used to scale the intensity of the current Cue.

### 13.80 Altering the Playback Order

Cues normally run in a sequential order or according to the settings in the NEXT field of each Memory and Chase. However, it is possible to quickly move forward or backwards in a Stack to run a different Cue.

To run a Cue other than the one showing above the Go button:

1. Press the Assign button followed by the Memory (or Chase) button.
2. Enter the required Memory / Chase number.
3. Press the Stack Go button.

The required Memory is now ready as the next Memory. Pressing the GO button will initiate Infade.

### 13.90 The SMaster / Hold Master

The SMaster on the Event Plus and the Hold Master on the Event are multipurpose controls which perform a number of functions:

- \* **Master:** As a Submaster to scale the overall level of the Assign Master faders
- \* **Hold:** To Hold and control a “snapshot” of the console output
- \* **XFade:** As a manual Crossfade control
- \* **Assign:** As an additional Assign Master controlling a Memory or Chase

#### 13.91 To Set the Operation of the Hold / SMaster

 **Diagram 13H**

- ❶ Press the Setup button to open the Setup Menu.
- ❷ Move the cursor to the CTRL (Controls) field.
- ❸ Press the + (On) button to open the Set Control menu.
- ❹ Move the cursor to the SMAST field.
- ❺ Press the + (On) button to toggle between Master / Hold / Xfade / Assign.
- ❻ Press Exit to close this menu (press twice to return to the standard screen).

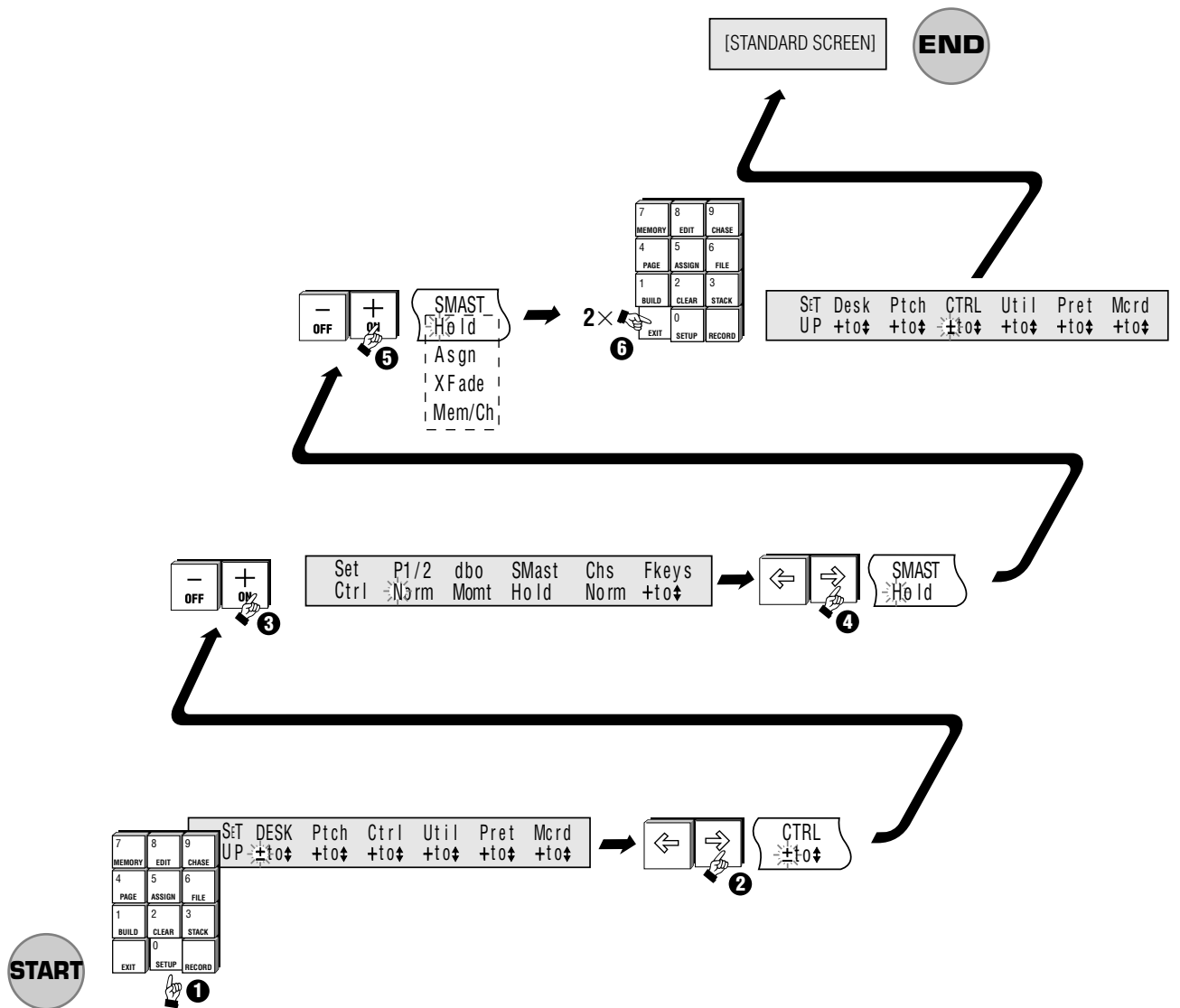

▲ 13H To Set the Operation of the Hold/SMaster

### 13.92 SMaster as Assign Faders Master

1. Check that the ASSIGN LED is lit.
2. The SMaster fader scales the intensity of the Assign Master faders.

**Example:** (Grand Master at 100%)

*Assign Master 1 includes Channel 1 at 90%, Assign fader 1 is set to 80% and the SMaster is set to 50%. The resultant intensity of the output from channel 1 is 36%:*

$$0.9 \times 0.8 \times 0.5 = 0.36 \text{ (36\%)}$$

### 13.93 SMaster as Hold Master

The Hold function is used to control the console output while changing Pages or to store a special look that is used at the end of each song.

1. Check that the Hold LED is lit. If the LED in the Sample button is lit, press the button to clear it.
2. Set up a console output using the Preset (or Assign) faders.
3. Press the Sample button. This takes a “snapshot” of the console output and the LED in the Sample button lights.
4. Fade the Preset and Assign faders to 0.
5. Grand Master at 100%.
6. The SMaster fader can now be used to fade the “snapshot” up and down.

### 13.94 SMaster as Manual Crossfade Master

Use manual crossfades to achieve a smooth transition between any Memories currently on the Assign faders

1. Check that the SMASTER field in the Setup Control menu is set to XFADE. Check that the fader is at zero.
2. Press and hold the button above the SMaster fader.
3. Press the Flash button beneath any of the Assign faders.
4. Release both buttons.
5. Move the SMaster fader up to fade in the chosen Memory.
6. Repeat steps 2 ~ 4 to chose another Memory.
7. Move the SMaster fader down to perform a dipless crossfade between the two Memories.

### 13.95 SMaster as Memory / Chase Control

Use the SMaster as an extra Assign Master when all other Assign Masters are occupied.

1. Check that the SMASTER field in the Setup Control menu is set to MEM /CH.
2. Press the Assign button followed by the Memory or Chase button.
3. Select a Memory or Chase number.
4. Press the button above the SMaster fader.
5. The SMaster controls now control that Memory / Chase in the same way as the Assign faders.

## **14.00 Overall Master Controls**

### **14.10 P1 and P2 Faders**

The P1 Master fader scales the top row of Preset faders, likewise the P2 Master fader scales the overall level of the bottom row of Preset faders. By moving the P1 fader up while moving the P2 fader down it is possible to crossfade between the settings on the two rows of channel Preset faders.

### 14.11 Reversing the P2 Master Fader

 **Diagram 14A**

Some operators who use the Preset faders while running a show prefer to move the two Preset Master faders together, with one hand, to crossfade between Presets. To allow this on an Event the Preset 2 Master fader can be reversed such that at the top of its travel output from Preset 2 is zero (0) and at the bottom of its travel the output is 100%.

To change the P2 master:

- ❶ Press the Setup button to open the Setup Menu.
- ❷ Move the cursor to the CTRL (Controls) field.
- ❸ Press the + (On) button to open the Set Ctrl menu.
- ❹ Move the cursor to the P1/2 field.
- ❺ Press the + (On) button to toggle between NORM (Normal) and REV (Reverse).
- ❻ Press Exit to close this menu (press twice to return to the standard screen).

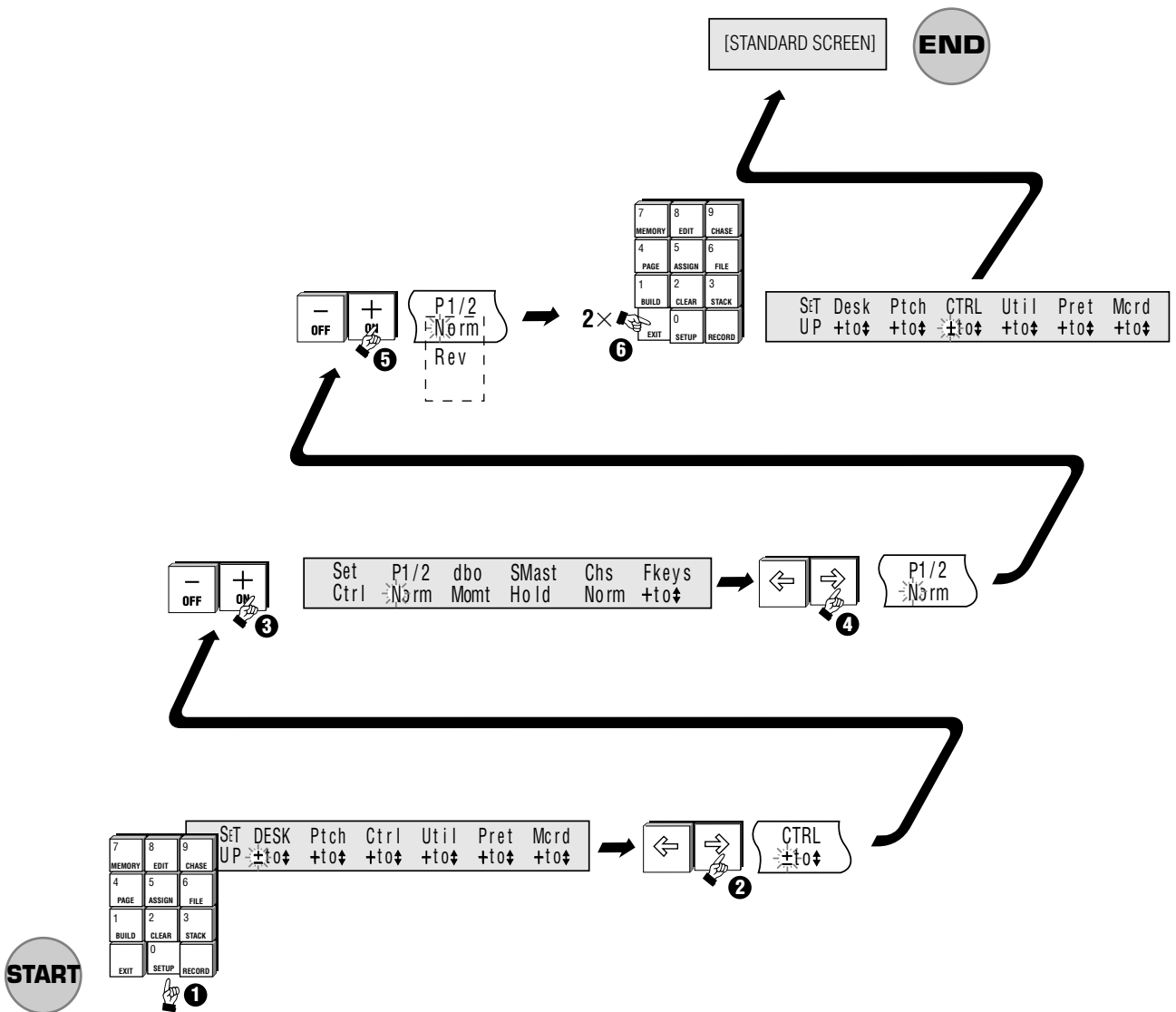

▲ 14A Reversing the P2 Master Fader

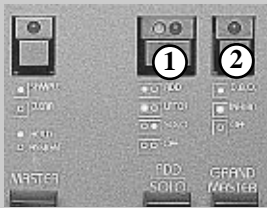

▲ 14B Add/Solo switch,  
DBO switch.

### 14.20 Add / Solo Master Switch

#### Diagram 14B ①

The Flash buttons can be set to operate in three different ways or turned off completely. To change the operation of the Flash buttons press the Add / Solo switch. With each press of the button, the two LEDs within the switch change to indicate which mode has been selected.

- \* **Add:** Indicated by the Green LED. Pressing a Flash button causes that output to flash instantly to the level set by the Add/Solo Master fader.
- \* **Add Latch:** Indicated by the Green LED Flashing. The Flash buttons push-on and push-off instead of flashing. When a Flash button is latched on, the channel LED will flash synchronously with the Add / Solo switch LED. If Add Latch is disabled while some channels are latched, the channels will unlatch but will not become latched again if Add Latch is subsequently enabled.
- \* **Solo:** Indicated by the Red LED. Pressing a Flash button causes that output to flash instantly to the level set by the Add/Solo Master fader, while at the same time turning off all other desk output.
- \* **Disabled:** Indicated by neither LED being on. Pressing a channel Flash button has NO effect.

### 14.30 DBO Switch

#### Diagram 14B ②

This button performs two functions:

- \* **Blackout**

When the button is pressed the entire output of the console is blacked out. The button can be set to:

***Momentary** - the console is Blacked Out only while the DBO button is depressed.*

**OR**

***Latching** - the console is Blacked Out by pressing the DBO button. Output is restored when the DBO button is pressed again.*

- \* **Inhibit**

To prevent a channel from appearing in any output, hold a channel Flash button down and press the DBO button.

### 14.51 To change the operation of the DBO switch from LTCH to MOMT:

1. Press the Setup button to open the Setup Menu.
2. Move the cursor to the CTRL (Controls) field and press the + (On) button to open the Set Control menu.
3. Move the cursor to the DBO field and press the + (On) button to toggle between MOMT (Momentary) and LTCH (Latching).
4. Press Exit to close this menu (press Exit several times to close all menus).

**NOTE:** When a channel is inhibited the LED in the associated Flash button flashes on and off. However, if the console is set for Wide or Super Wide operation it is not possible to inhibit the channels which do not have Flash buttons.

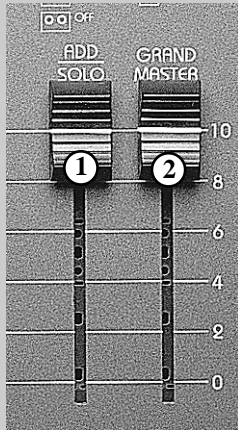

▲ 14C Add/Solo fader,  
Grand Master fader.



▲ 14D Rate Control

### 14.40 Add / Solo Fader

Diagram 14C ①

This fader controls the level of the Flash buttons.

### 14.50 Grand Master Fader

Diagram 14C ②

This fader controls the level of all console outputs except the Flash buttons.

### 14.60 Rate Control

Diagram 14D

The Rate Control scales the speed of all Chases that are running. This control should normally be set to the mid or 12 o'clock position. Chases will then run at the speed set in the Chase menu. Turning the control clockwise will speed the chase(s) up, turning the control counter clockwise will slow the chase(s) down.

## **Advanced Features**

---

# **Advanced Features**

# 15.00 Advanced Control

## 15.10 Build

When controlling moving lights and in some theatrical applications it can be useful to use Memories as “building blocks”. In this way Memories that have been “built” will reflect any changes made in the Memories they are built from. This feature is commonly used to simplify the refocusing of moving lights when moving from venue to venue.

A show might include a number of Memories that have moving lights focused on the lead singer. When the show moves to a new venue the trim height of the truss might be different or the singer might move to a slightly different position. Normally all Memories that had lights focused on the singer would have to be edited to correct the focus.

An easier solution is to record one Memory that focuses the lights on the singer - that memory ONLY contains Pan and Tilt information. After turning on the Build record feature the Memory is used when recording any other Memories that have the lights focused on the singer. Then if the focus needs to be changed its only necessary to edit the one memory, containing the pan and tilt information to see that change reflected in all the other memories that were built from it.

### **EXAMPLE:**

*The steps below detail an example of how to record a Memory that only includes position settings and how to build from that Memory:*

1. Record a Memory that only controls the Pan and Tilt settings for a number of lights.

**NOTE:** To do this you'll need to have the light on and the iris open so you can see where it is being focused but remember to pull all the preset faders, except those controlling Pan and Tilt, down to zero before recording the Memory. That way only the channels controlling Pan and Tilt will be recorded with a level greater than 0.

2. Open the Build menu and set the Record field to Build.
3. Make sure the Memory you recorded at step 1 is on the Assign masters. Fade up the Memory to position the lights.
4. Use the Preset Faders to set Colour, Intensity and so on.
5. Record a new Memory.

*This new Memory will now track any changes made to the Memory it was built from.*

**NOTE:** Built memories are NOT automatically updated if they are on the Assign masters. The Built memory MUST be reloaded to the Assign faders by changing Page or Assigning.

## 15.20 To see the changes in a Built Memory

There are two Methods to see changes in a Built Memory:

### METHOD 1

1. Edit the Memory that is being Built from (i.e. in our example the focus Memory)
2. Assign the Built memory to one of the Assign faders.

**NOTE:** If the Built Memory is already on an Assign fader just Assign the same Memory over the top of it.

### METHOD 2

1. Load the Page containing the Built memory

**NOTE:** If the Built Memory is part of the Page on the Assign faders just reload the same Page.

2. Fade in the Built memory to see the changes.

**TIP:** After recording a number of position memories, set them up as a Stack so that when recording Built Memories you can 'scroll' through various position settings. Colour and Beam information can also be recorded and used in the same way.

### 15.30 Other Build Menu Features

The Build menu also includes a From field. This allows you to isolate the Assign master output from the recording process.

When the From field is set to All any output from the console is included in a Memory. However when the From field is set to Presets only the levels coming from the Preset faders are recorded. If an Assign master is faded up it is ignored.

This feature is designed to make recording Position memories easier. The example below shows how.

***Example - Moving Lights***

1. *Set the FROM field to All.*
2. *Set the RECORD field to Normal.*
3. *Choose a number of moving lights which will normally be used in a group.*
4. *Use the presets controls to turn the lights on, open the iris and do whatever else is necessary for you to be able to see the light BUT make sure you leave the Pan, Tilt, Colour and Gobo controls at zero.*
5. *Record this output and Assign the Memory to one of the Assign Masters.*
6. *Set the FROM field to Preset.*
7. *Set the RECORD field to Build.*

Now this Memory can be left up on an Assign fader to let you see the lights while you record some position Memories as detailed above.

## 15.40 Edit Memory

### 15.31 Recording Theatrically- Using Edit Memory Menu

Many theatre lighting consoles do not have individual channel faders. To record Memories on these consoles the operator uses a keypad and enters channel numbers and level settings:

eg. CH# - TO# - At  
1 - 10 - 50

(channel 1 to channel 10 at 50% intensity)

Event offers this quick and convenient method through the Edit Memory (or Edit Chase) menu:

1. Press the Edit button then press the Memory button.
2. Enter the Memory number (0 - 999) to be recorded.
3. Enter new level values into the menu's CH# - TO# - AT fields.

**NOTE:** As each channel or group of channels is adjusted using either edit method, the changes are stored temporarily so there is no need to press Record to save each individual change.

4. When all settings have been made press the Record button. If you want to abandon all the changes and start again, press Exit.
5. A message displays on the LCD showing the number of Memories recorded and the number still available for future recording.

**TIP:** Unless the Memory is already recorded you will not be able to put the Memory on an Assign fader and so be able to see what you are doing.

To get around this problem it's possible to assign the edit output to a fader:

- Press the Assign button followed by the Edit button.
- Press the Flash button beneath the Assign fader to be used to control the Edit output.

Once the Flash button has been pressed, the Assign menu is closed and you will see the Edit output has replaced whatever was previously controlled by the Assign Master.

### 15.50 Edit Page

#### 15.51 Changing the Make-up of a Page:

 **Diagram 15B/Examples 1, 2, 3**

It is possible to change the default make-up of a Page by using the Edit Page menu. This menu is used to configure the make up of Pages so as to set how many Memories will be included in a Page. The numerical increment between the first Memory in each Page and whether Chases will automatically be loaded with each Page, can be altered by this procedure:

- 1 Press the Edit button.
- 2 Press the Page button.
- 3 Move the cursor to the MEMS field.
- 4 Use the + (On)/- (Off) button or keypad to enter the number of Memories per Page (1 - 24).
- 5 Move the cursor to the INCR (Increment) field.
- 6 Using the + (On)/- (Off) button or keypad to enter the number of the increment between the first Memory in each Page.
- 7 Move the cursor to the CHS: (Chase) field.
- 8 Use the + (On) button to change from AUTO to OFF or vice versa. When Auto is selected a Chase is automatically loaded to Assign Master 21 whenever a new Page is loaded. The Chase number corresponds to the Page number.
- 9 Press the Exit key to return to the standard screen.

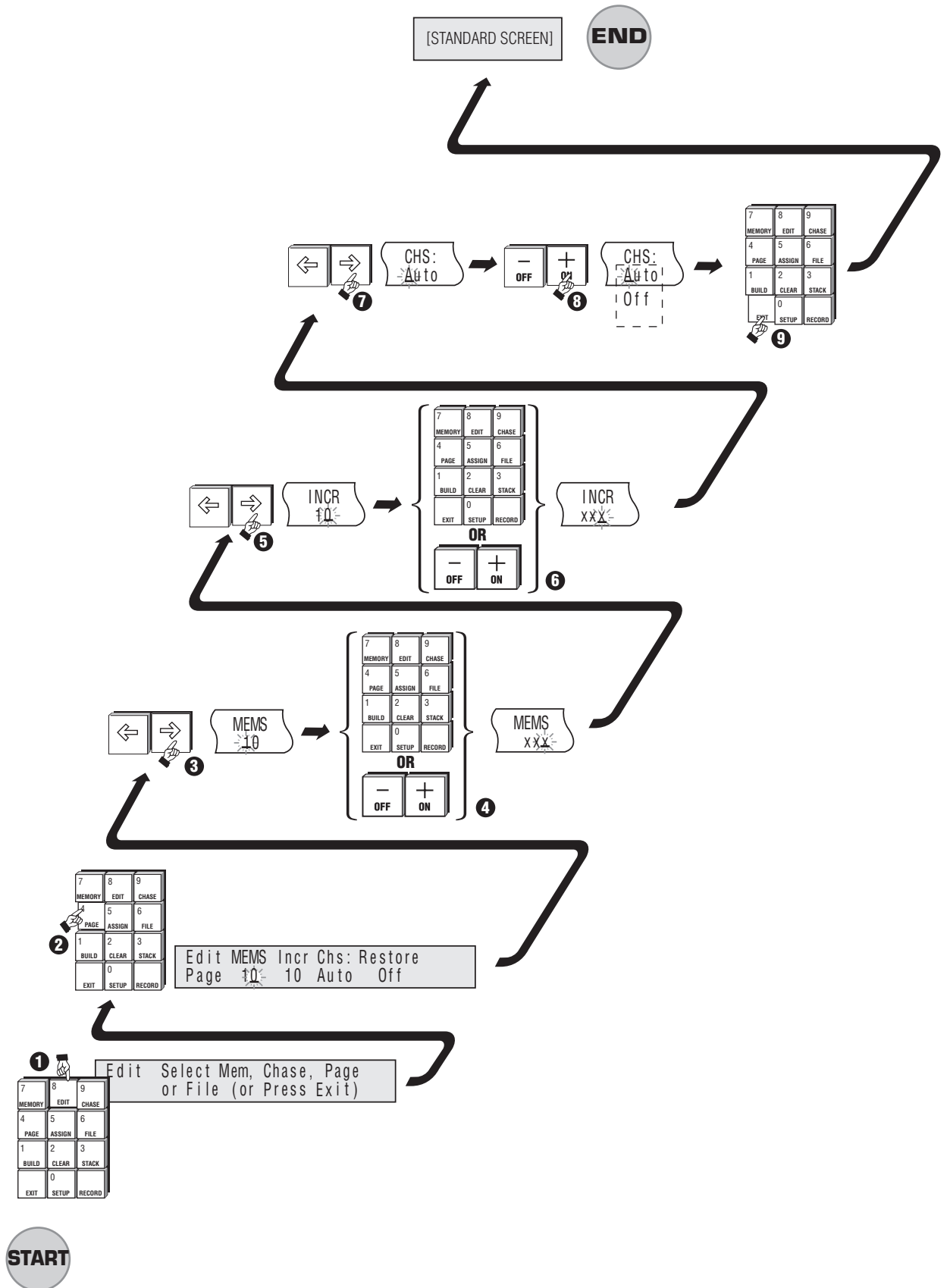

▲ 15B Edit page

## Advanced Features

### Example 1:

When shipped from the factory the Event Plus has the EDIT PAGE menu set as described below. The makeup of each Page will be:

Page #	Assign Faders	Control
0	1 - 20 21	Memories 0 - 19 Chase 0
1	1 - 20 21	Memories 20 - 39 Chase 1
2	1 - 20 21	Memories 40 - 59 Chase 2
10	1 - 20 21	Memories 200 - 219 Chase 10

### Example 2:

The Number of Memories can be changed to suit particular applications. A show might call for a number of Stacks and Chases to be permanently set on Assign faders 12 - 24. In this case the operator can set the number of Memories per Page to 10 with an Increment of 10. The Auto Chase load is left on in this example - note that it loads on the next fader after the last memory.

Page #	Assign Faders	Control
0	1 - 10 11	Memories 0 - 9 Chase 0
1	1 - 10 11	Memories 10 - 19 Chase 1
2	1 - 10 11	Memories 20 - 29 Chase 2
10	1 - 10 11	Memories 100 - 119 Chase 10

### Example 3:

The Increment between the first Memory of each Page can be changed to suit a particular numbering scheme or to allow overlapping Pages. In this case Memories per Page has been set to 20 and the Increment to 100. Chase is on Auto.

Page #	Assign Faders	Control
0	1 - 20 21	Memories 0 - 19 Chase 0
1	1 - 20 21	Memories 100 - 119 Chase 1
2	1 - 20 21	Memories 200 - 229 Chase 2
5	1 - 20 21	Memories 500 - 519 Chase 10

**NOTE:** If the CHS: field is changed from AUTO to OFF, no Chases are loaded with each Page.

### 15.42 Restoring the Factory Settings for Page

To restore the default settings for EDIT PAGE :

1. Press the Edit button.
2. Press the Page Button.
3. Move cursor to the RESTORE field.
4. Press the + (On) button to set the restore function "ON".
5. Press Exit to return to the standard screen.

## 15.60 Edit File

### 15.61 Changing the Default File Settings

It is possible to change the way Files work using the Edit File menu.

However, this is an advanced feature and will probably not be required by most users. The Edit File menu is used to limit the number of Assign Masters that will be loaded when a new File is loaded.

**Note:** When a File is saved ALL the settings of the Assign Masters are saved. Edit File is only used to limit the number of Assign faders that are updated by loading a File.

1. Press the Edit button then press the File button.
2. With the cursor in the FIRST field, set the Assign Master fader number which will be the first of a group to be loaded with the contents of a File.
3. Move the cursor to the LAST field, set the Assign Master fader number which will be the last of a group to be loaded with the contents of a File.
4. Press the Exit key

**Example:**

*The operator might want to use the first six memories stored in a file. However, when this file is loaded to the Assign Masters, the remaining 18 Assign Masters are not to be changed. Set the FIRST field to 1 and the LAST field to 6.*

### 15.62 Restoring The Factory Settings for File

To restore the default settings for Edit File:

1. Press the Edit button then press the File button.
2. Move the cursor to the RESTORE field.
3. Press the + (On) button.
4. Press the Exit key.

### 16.00 Restricting Access to Various Menus and Controls

It is possible to limit the access a user has to the Event menus and controls:

1. Press the Setup button to open the Setup menu.
2. Move the cursor to the DESK field and press the ON (+) button to open the Set Desk menu.
3. Move the cursor to the MODE field and press the ON (+)/OFF (-) button to toggle between REC and PLAY.

In the PLAY mode the following menus and menu fields are not available:

Memory	Edit	Chase
Page Label	Page Chs 1	Page Chs 2
File Save	Patch	Clear
File Label	MCard	

In the Record mode all console functions are available.

**TIP:** The Event also allows a PASSWORD to be set so that it is not possible to change from PLAY to RECORD until the password has been correctly entered.

(To set a Password see [Section 23.00](#)).

## 17.00 Function Keys

Function keys are only available on the Event Plus consoles. The right hand bank of Assign Master Flash buttons become Function Keys whenever Function Keys are enabled.

Any operation that involves numerous button presses can be simplified by the use of Function Keys (Macros). That way, pressing one button will reproduce the actions of up to 30 button presses.

**TIP:** Use Macros to speed up recordings by having words as Macros, e.g. RAYS, WASH, or use Macros to change to the next page during a show.

### 17.10 To Record a Function Key.

 Diagram 17A

- 1 Press the Setup button to open the Setup Menu.
- 2 Move the cursor to the CTRL (Control) field.
- 3 Press the + (On) button to open the Set Control menu.
- 4 Move the cursor to the FKEYS (Function Keys) field.
- 5 Press the + (On) button to open the Set Function Keys menu.
- 6 Move the cursor to the ENABLE field.
- 7 Press Exit to close this menu (press Exit several times to close all menus).
- 8 Ensure that the Add/Solo Master switch is Off.
- 9 Press one of the Flash buttons on the right hand bank of Assign Masters. The LED in the button will turn on.
- 10 Press the sequence of button presses to be recorded.
- 11 Press the Assign Master Flash button again. The LED in the button will turn off.

### 17.20 To Play Back a Function Key

1. Ensure that the Add/Solo Master switch is Off.
2. Press the same Assign Master Flash button as used to record the sequence.
3. The recorded sequence will be replayed.

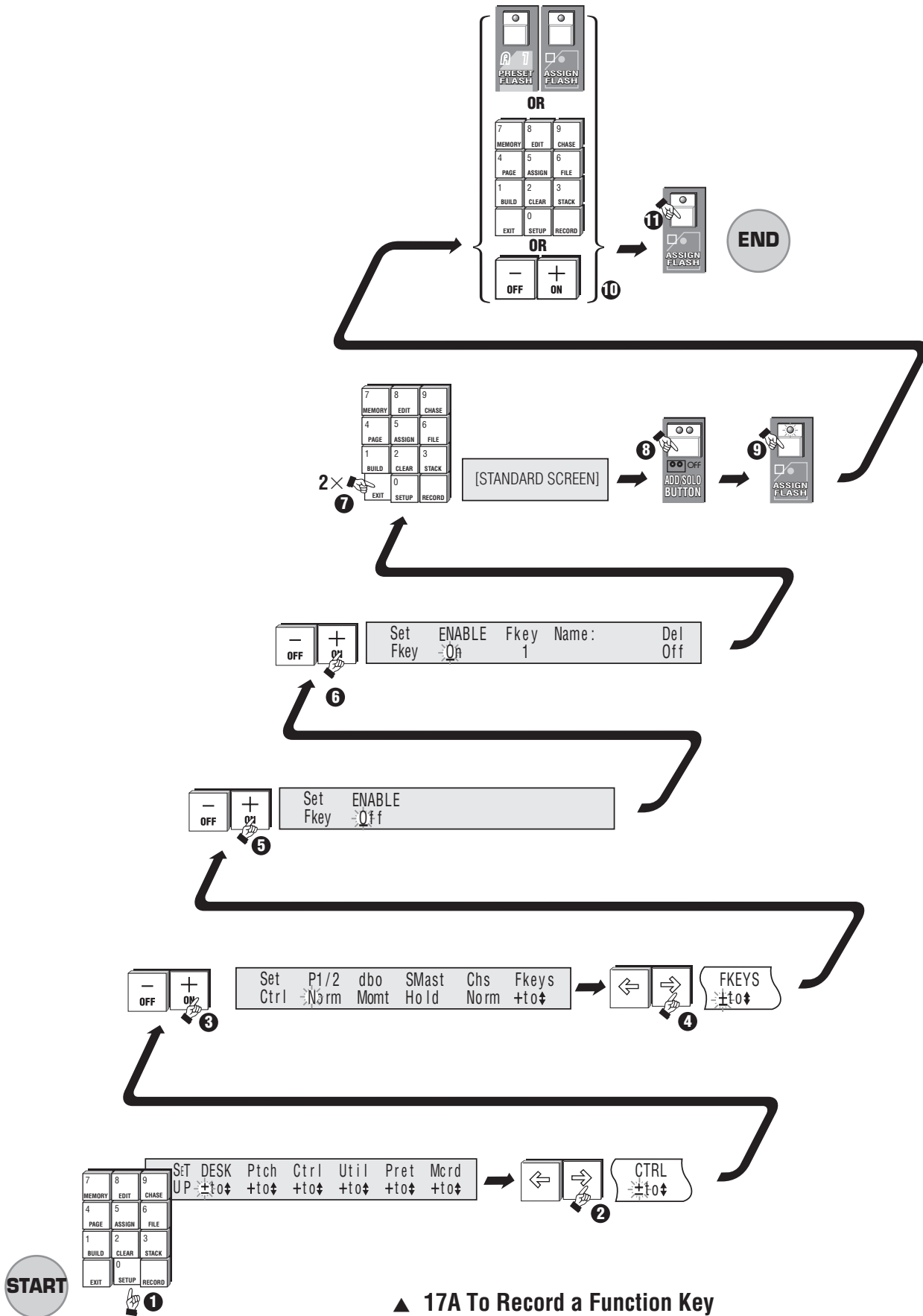

▲ 17A To Record a Function Key

# 18.00 Advanced Channel Control

## 18.10 Setting Channels to Ignore Crossfade Timing

When a timed crossfade is being used it can be useful to set some channels to ignore the timing information. For example, you might want to snap change a colour scroller while slowly fading the intensity.

### 18.11 To Set Channels to Ignore Timing:

 **Diagram 18A**

- ➊ Press the Setup button to open the Setup Menu.
- ➋ Move the cursor to the UTIL (Utilities) field.
- ➌ Press the + (On) button to open the Set Utilities menu.
- ➍ Move the cursor to the PREC (Precedence) field.
- ➎ Press the + (On) button to open the Setup Precedence menu.
- ➏ Move the cursor to the CHAN# field and set a start channel number.
- ➐ Move the cursor to the THRU (Through) field and set an end channel number.

**TIP:** If you just want to set one channel, leave this field the same as the CHAN# field.

- ➑ Move the cursor to the PREC field and set it to LAST.
- ➒ Repeat steps ➋ to ➑ for any other channels or groups of channels.
- ➓ Press Exit to close this menu (press Exit several times to close all menus).

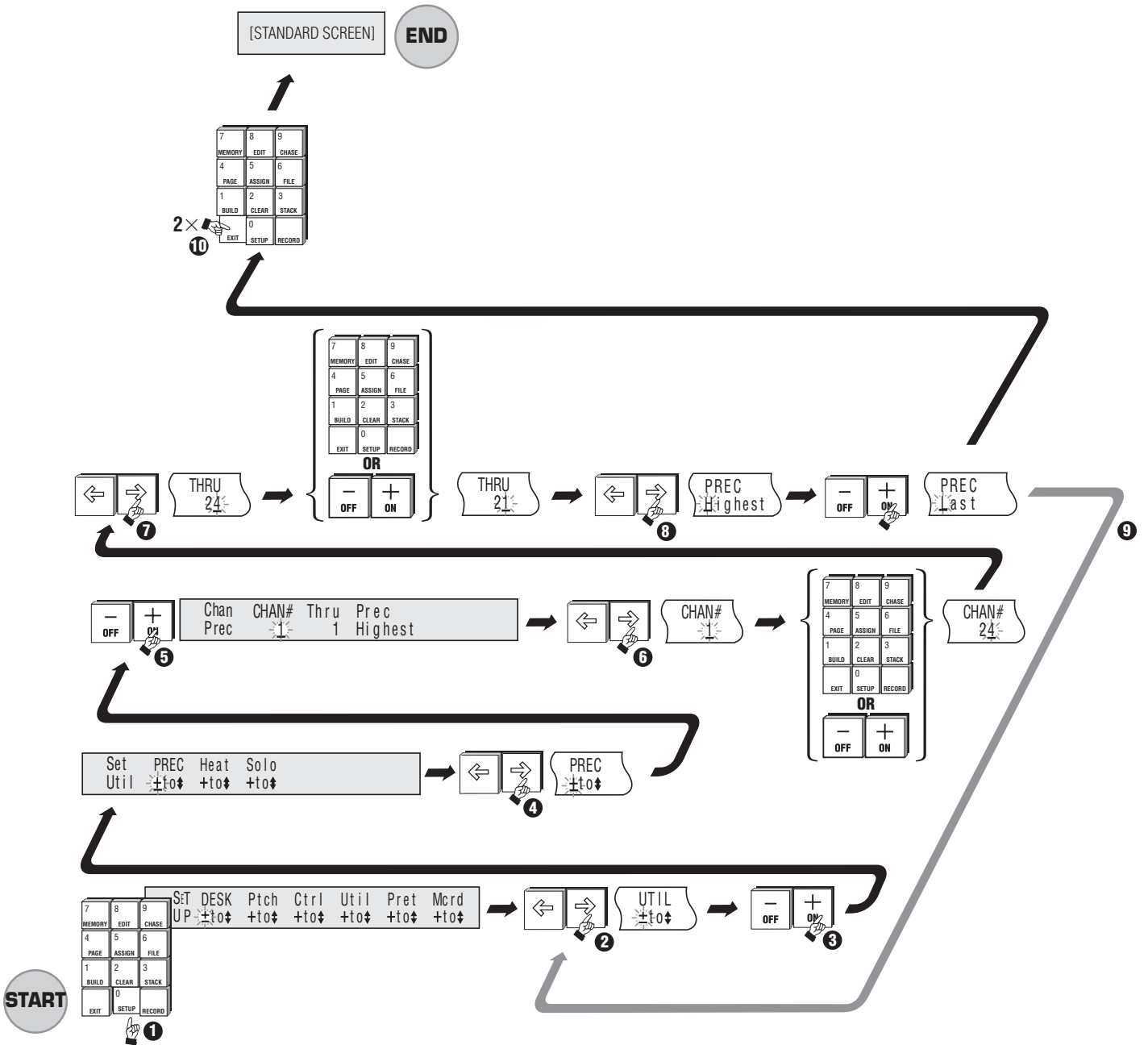

▲ 18A To Set Channels to Ignore Timing

### 18.20 Setting Channels to Always Have a Back - Ground Intensity - Preheat

Some lamps with large filaments (such as aircraft landing lights) are slow to turn on. The turn on response of such lamps can be improved by maintaining a small voltage to them which warms the filament.

#### 18.21 To Set Channels to Preheat the Filament:

 **Diagram 18B**

- 1 Press the Setup button to open the Setup menu.
- 2 Move the cursor to the UTIL (Utilities) field.
- 3 Press the + (On) button to open the Set Utilities menu.
- 4 Move the cursor to the HEAT (Preheat) field.
- 5 Press the + (On) button to open the Setup Preheat menu.
- 6 Move the cursor to the DIM# field.
- 7 Set a start dimmer number.
- 8 Move the cursor to the THRU (Through) field and set the end dimmer number.

**TIP:** If you just want to set one dimmer, leave this field the same as the DIM# field.

- 9 Move the cursor to the AT field.
- 10 Set it in the range 1 - 10%.
- 11 Repeat steps from 2 to 11 for any other dimmers or groups of dimmers.
- 12 Press Exit to close this menu (press Exit twice to return to the standard screen).

**TIP:** Setting preheat to 5% for example, will cause the dimmer to output about 10 volts.  
Setting preheat to around 2% usually does not cause any visible glow.



### 18.30 Setting Channels to Ignore Flash Button Solo Operation

 **Diagram 18C**

Pressing A Flash button when in Solo mode will cause all other console channels to “black out”. This can cause unwanted effects on channels controlling moving lights or colour changers.

To set channels to ignore Solo:

- ❶ Press the Setup button to open the Setup menu.
- ❷ Move the cursor to the UTIL (Utilities) field.
- ❸ Press the + (On) button to open the Set Utilities menu.
- ❹ Move the cursor to the SOLO field.
- ❺ Press the + (On) button to open the Setup Channel Solo menu.
- ❻ Move the cursor to the CHAN# (Channel) field.
- ❼ Set a channel number.
- ❽ Move the cursor to the THRU (Through) field.
- ❾ Set an end channel number.

**Note:** If you just want to set one channel, leave this field as same as the CHAN# field.

- ❿ Move the cursor to the SAFETY field.
- ⓫ Set it to ON.
- ⓬ Repeat steps from ❷ to ❾ for any other channels or groups of channels.
- ⓭ Press Exit to close this menu (press Exit twice to return to the standard screen).

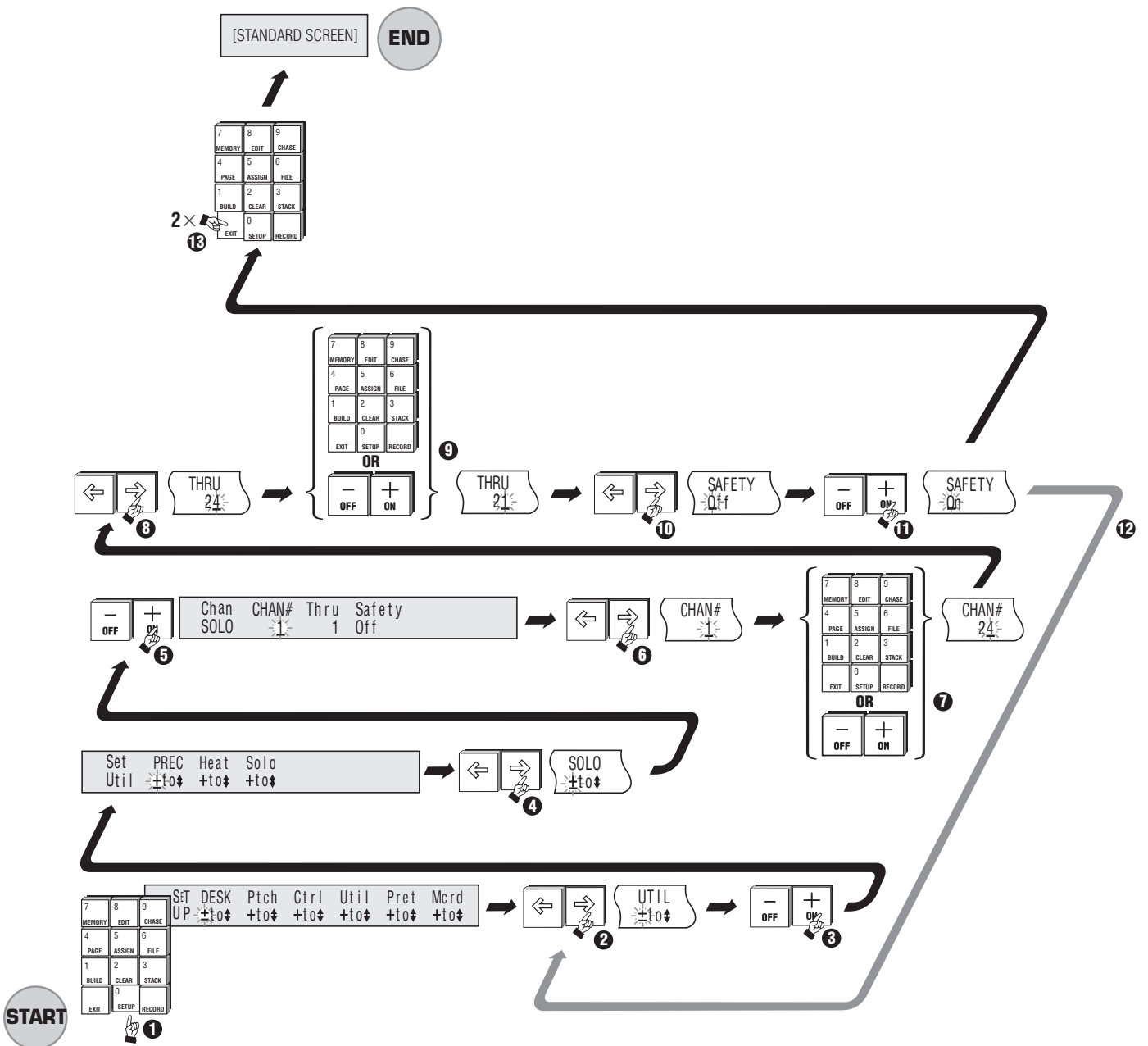

▲ 18C Setting Channels to Ignore Flash Button Solo Operation

# 19.00 Advanced Desk Options

## 19.10 Setting Default Infade and Outfade Times

 **Diagram 19A**

Before recording Memories that will be used in a crossfade Stack it can be convenient to set default fade times to avoid the necessity of setting times for each Memory.

**Note:** Default times will only be added to new Memories. It is possible to change the setting for any Memory later.

- ① Press the Setup button to open the Setup menu.
- ② Move the cursor to the PREF (Preferences) field.
- ③ Press the + (On) button to open the Set Preferences menu.
- ④ Move the cursor to the TIMES field and set a time in the format MM:SS or M:SS.s (M=minute, S=seconds, s = tenths of a second).
- ⑤ Press Exit to close this menu (press Exit several times to close all menus).

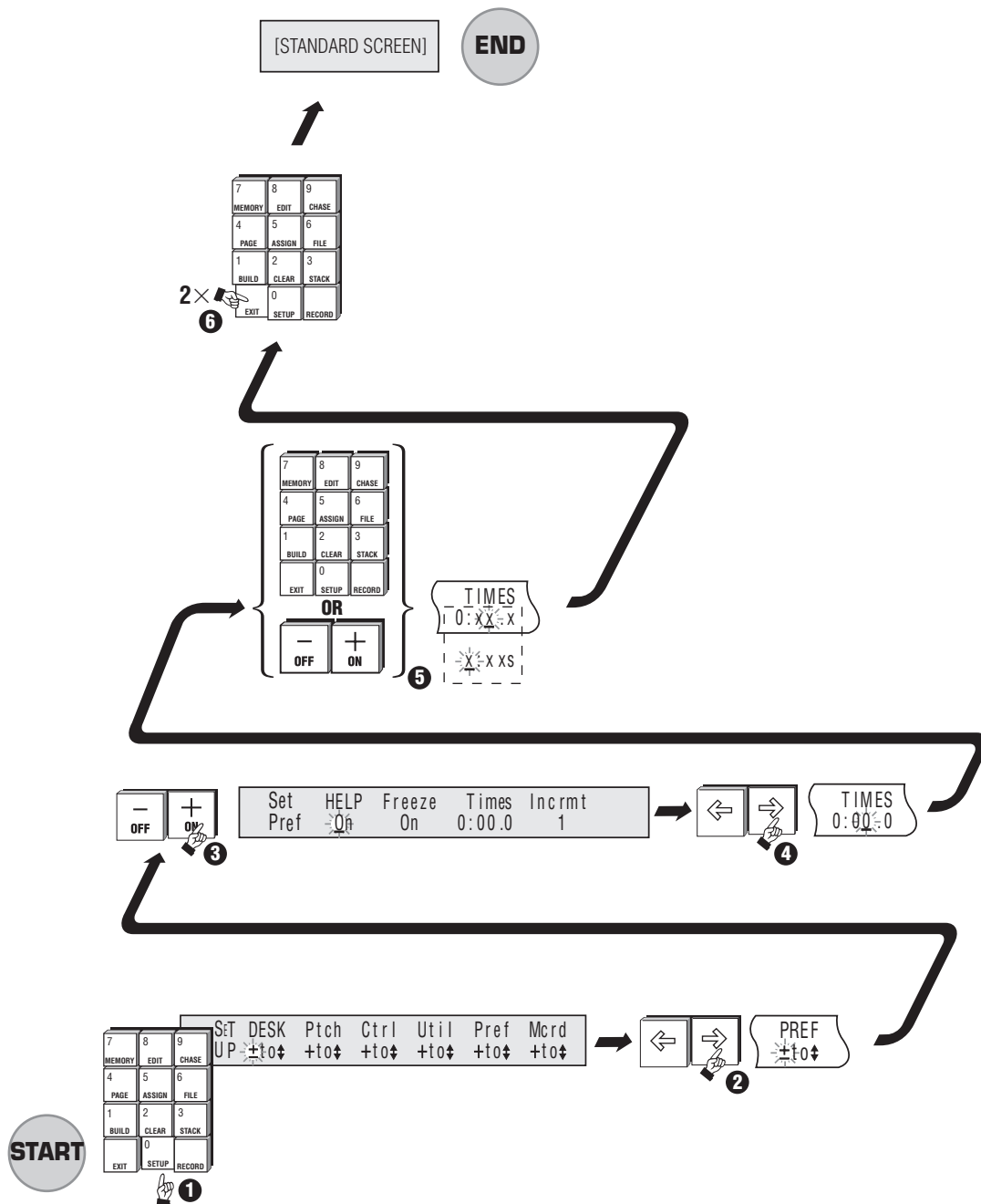

▲ 19A Setting Default Infade and Outfade Times

### 19.20 Changing the Increment Between Memories When Recording

Normally when a Memory is recorded the Memory menu automatically advances to the next Memory number, allowing a number of Memories to be quickly recorded.

However it can be useful to change the increment between Memories when the menu advances.

1. Press the Setup button to open the Setup menu.
2. Move the cursor to the PREF (Preferences) field and press the + (On) button to open the Set Preferences menu.
3. Move the cursor to the Incr (Increment) field and set an Increment between 1 and 10.
4. Press Exit to close this menu (press Exit several times to close all menus).

**Example:**

*Normally when Memories are recorded (using the Memory menu) the Memory number automatically advances by 1 after the Record button is pressed. However, in first plotting a show which is to be run using the crossfade controls, you might want to leave a number of free Memories between each Memory being recorded, to make it easier to insert extra cues at a later time.*

**TIP:** If the increment was set to 10 and the first Memory recorded was M 10 the Memory menu would advance to M 20. The Memory number can still be set to any intermediate value by typing the required number from the keypad.

### 19.30 Turning the Help Screen On and Off

The help screen which displays on the LCD to the left of the menu LCD can be turned off when the user becomes more familiar with the console.

1. Press the Setup button to open the Setup menu.
2. Move the cursor to the Pref (Preferences) field and press the + (On) button to open the Set Pref menu.
3. Move the cursor to the Help field and press the – (Off) button to turn Help off, or press the + (On) button to turn Help back on.
4. Press Exit to close this menu (press Exit several times to close all menus).

## 20.00 Using the MCard - Option

The Event MCard is an optional accessory which allows all the information recorded in the console to be saved to a compact RAM disk. Anyone who regularly runs the same show is strongly advised to fit an MCard. It is not possible to access the MCard menu unless the console is fitted with the MCard option panel.

### 20.10 To Open the MCard Menu

1. Press the Setup button to open the Setup menu.
2. Move the cursor to the MCARD field and press the + (On) button to open the Set MCard menu.

**NOTE:** If the MCard option is not fitted, it is not possible to activate the MCard menu.

### 20.20 To Save the Information Recorded in the Event:

1. First ensure that the MCard battery is fitted and the write enable switch is on, then insert the MCard in the rear panel slot.
2. Open the MCARD menu as detailed above.
3. Move the cursor to the TO MCARD field and press the + (On) button.
4. A record confirmation screen shows.
5. Press Exit to close this menu.

### 20.30 Loading From the MCard.

When information is loaded from MCard all Memories, Chases and Patches are overwritten.

To retrieve information recorded on MCard to the Event:

1. First ensure that the MCard battery is fitted and the write enable switch is on, then insert the recorded MCard in the rear panel slot.
2. Open the MCARD menu as detailed above.
3. Move the cursor to the FROM MCARD field and press the + (On) button.
4. A loaded confirmation screen shows.
5. Press Exit to close this menu.

**NOTE:** Remove MCard from the slot immediately after loading from or saving to a MCard. Leaving the MCard in the slot while turning console On/Off may corrupt the information stored.

# 21.00 Clearing Memories, Chases and Patches

Memories and Chases can be cleared to free console Memory or prevent further use. Patches can be cleared to provide either a factory default (1 to 1) Patch or a no connection (Null) Patch.

## 21.10 Clearing Memories

 **Diagram 21A**

- 1 Press the Clear button to open the Clear/Copy Menu.

**NOTE:** Move the cursor to the Function field and press the ON (+) button to toggle the field from Copy to Clear if necessary.

- 2 Move the cursor to the MEM (Memory) field.
- 3 Press the + (On) button to open the Clear Memory menu.
- 4 Move the cursor to the MEM: (Memory:) field.
- 5 Set the Memory number to be cleared (deleted)
- 6 Move the cursor to the TO: field.
- 7 Set the last of a range of Memory numbers to be cleared (deleted).
- 8 Move the cursor to the CONFIRM field.
- 9 Press the + (On) button to delete the Memory block.

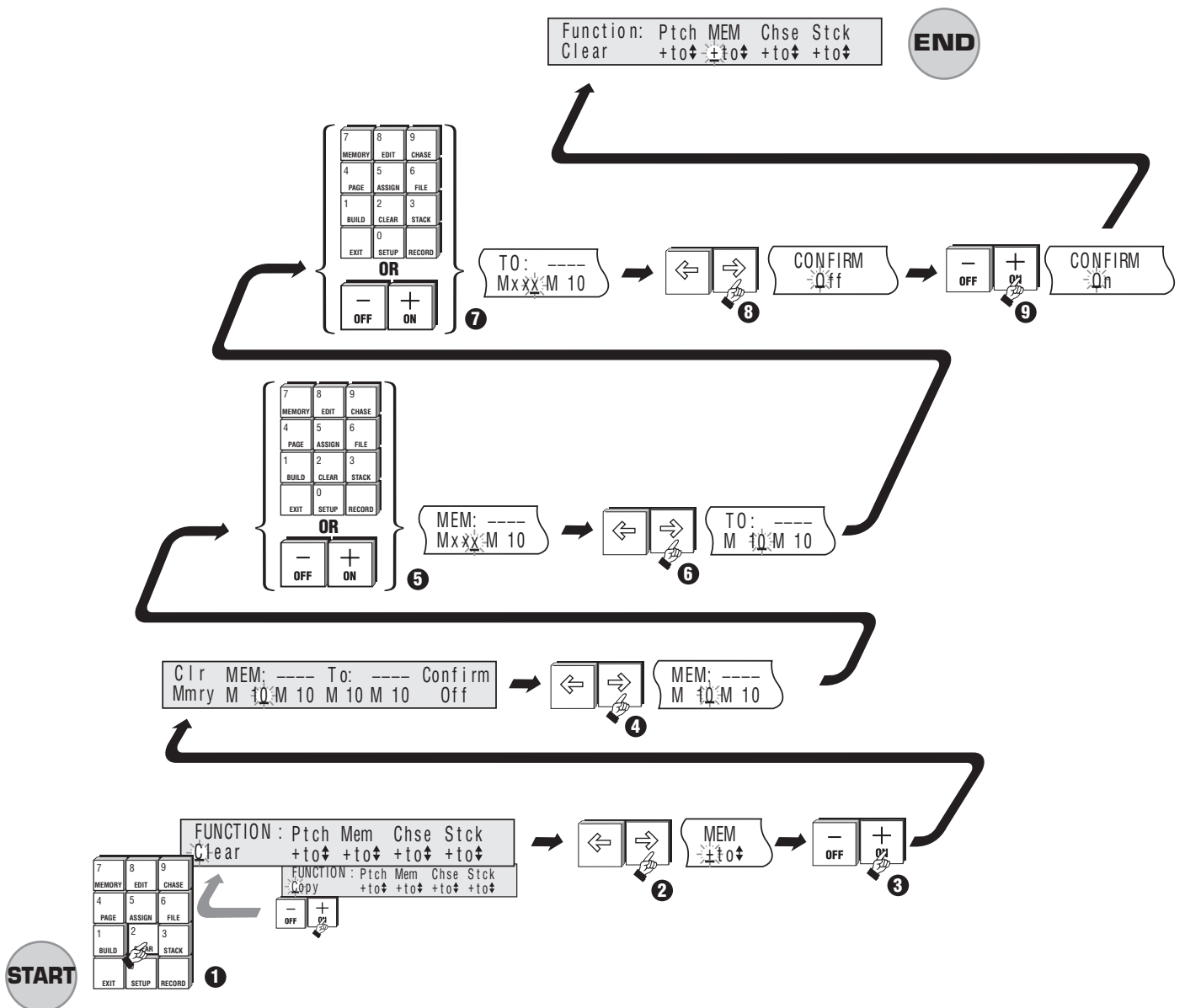

### ▲ 21A Clearing Memories

### 21.20 Clearing a Stack

This procedure is explained in the section on using Stacks (see Section [13.00](#)).

### 21.30 Clearing Chases

 **Diagram 21B**

- 1 Press the Clear button to open the Clear/Copy menu.
- 2 Move the cursor to the CHSE (Chase) field.

**Note:** Move the cursor to the **FUNCTION:** field and press the **ON (+)** button to toggle the field from Copy to Clear if necessary.

- 3 Press the + (On) button to open the Clear Chase menu.
- 4 Move the cursor to the CHS: (Chase:) field.
- 5 Set the Chase number to be cleared (deleted).
- 6 Move the cursor to the TO: field.
- 7 Set the last of a range of Chase numbers to be cleared (deleted).
- 8 Move the cursor to the CONFIRM field.
- 9 Press the + (On) button to delete the Chase(s).

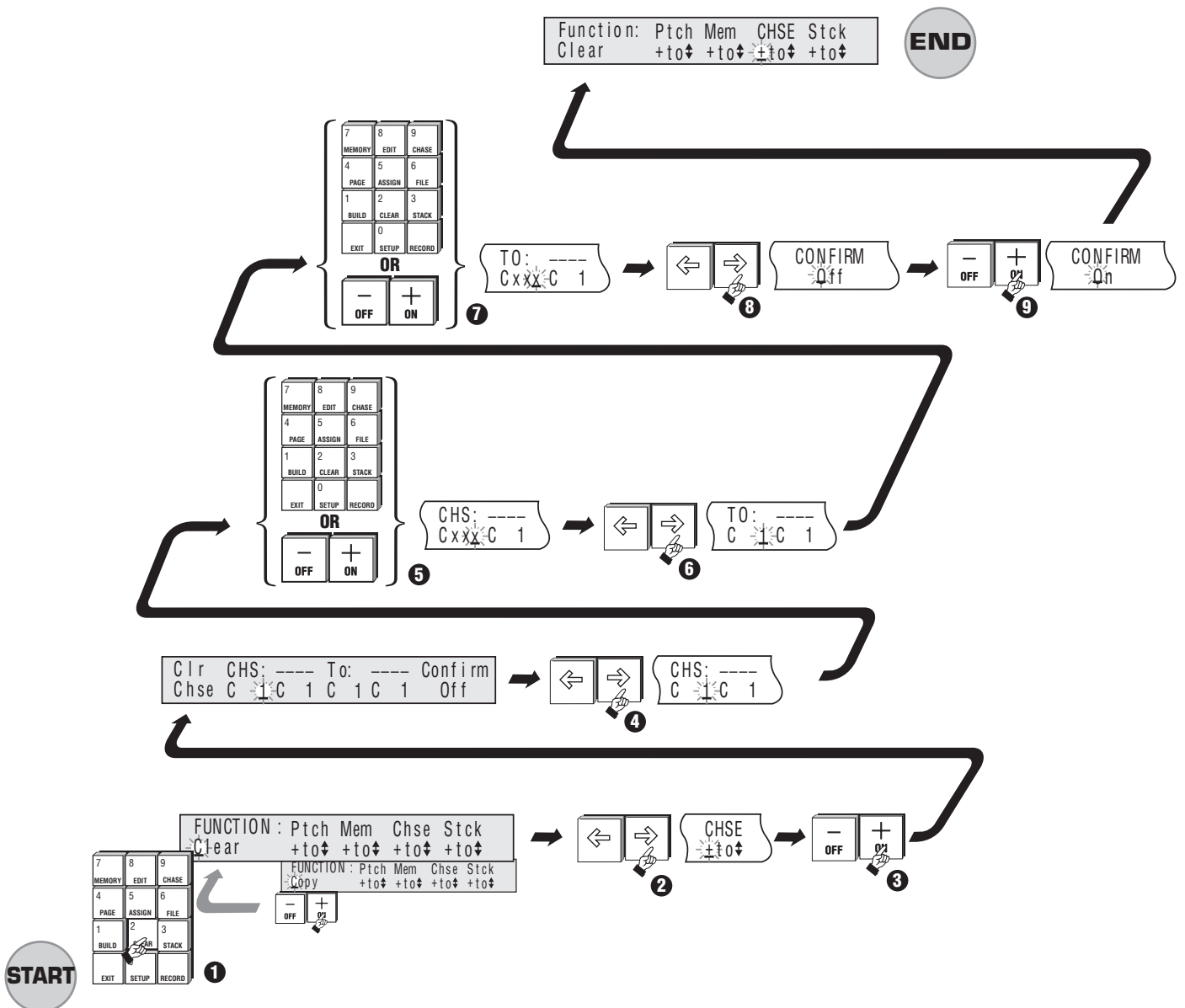

▲ 21B Clearing Chases

### 21.40 Clearing a Patch

 **Diagram 21C**

- 1 Press the Clear button to open the Clear/Copy menu.

**Note:** Move the cursor to the Function field and press the + (On) button to toggle the field from Copy to Clear if necessary.

- 2 Move the cursor to the PTCH (Patch) field.
- 3 Press the + (On) button to open the Clear Patch menu.
- 4 Move the cursor to the PCH: (Patch:) field.
- 5 Set the Patch number to be cleared.
- 6 Move the cursor to the Type field and set the type of Patch which will be formed after the old one is cleared. The **two** options are:

**1 to 1** - Patches Channel 1 to Dimmer 1, Channel 2 to Dimmer 2 and so on to the maximum number of desk channels. On a 48 Channel Event channel 48 is patched to dimmer 48 in normal mode and channel 96 is patched to dimmer 96 if in wide mode. Dimmers above this number are NOT patched to begin with.

**Null** - Does not patch any channel to any dimmer. It is sometimes easier to set up a new Patch by starting from a “clean slate”.

- 7 Move the cursor to the LVLS (Levels) field.
- 8 Set the default level for each dimmer in the Patch.

**For example:**

As shown in diagram 21C, if the field is set to 50 all dimmers would be patched at 50%. However, this level can then be changed on a dimmer by dimmer basis.

- 9 Move the cursor to the CONFIRM field and press the + (On) button to clear the Patch.

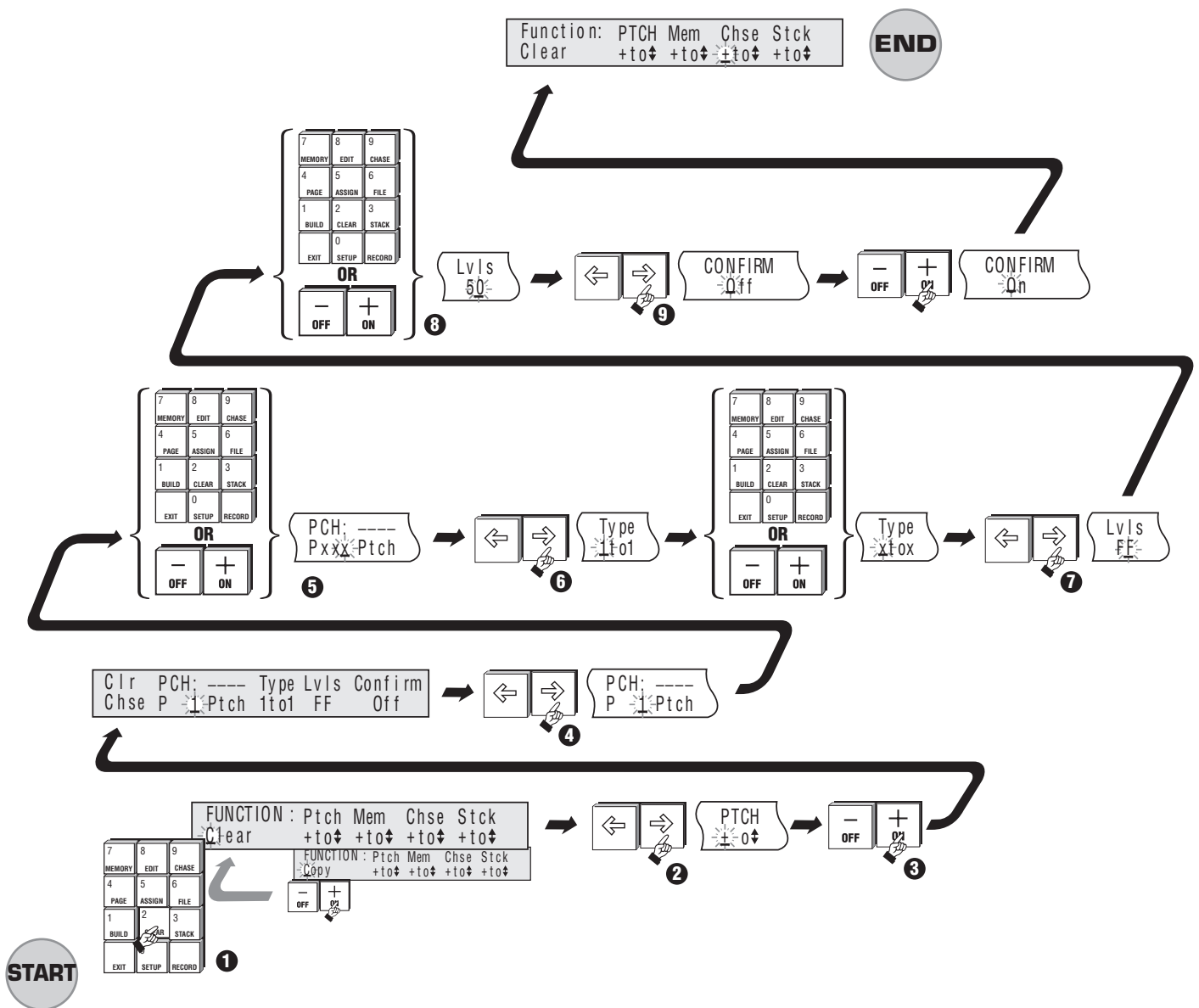

▲ 21C Clearing a Patch

## 22.00 Copying Memories, Chases and Patches

### 22.10 Copying a Memory

 **Diagram 22A**

- 1 Press the Clear button to open the Clear/Copy menu.

**Note:** Move the cursor to the **FUNCTION:** field and press the + (On) button to toggle the field from Copy to Clear if necessary.

- 2 Move the cursor to the MEM (Memory) field.
- 3 Press the + (On) button to open the Copy Memory menu.
- 4 Move the cursor to the MEM: field (the number of the memory to be copied).
- 5 Set the Memory number to be copied.
- 6 Move the cursor to the TO: field (the number where the memory is to go).
- 7 Set the Memory number to be copied to.
- 8 Move the cursor to the CONFIRM field.
- 9 Press the + (On) button to copy the Memory.

**Example:**

*Diagram 22A shows Memory 10 being copied to Memory 50.*

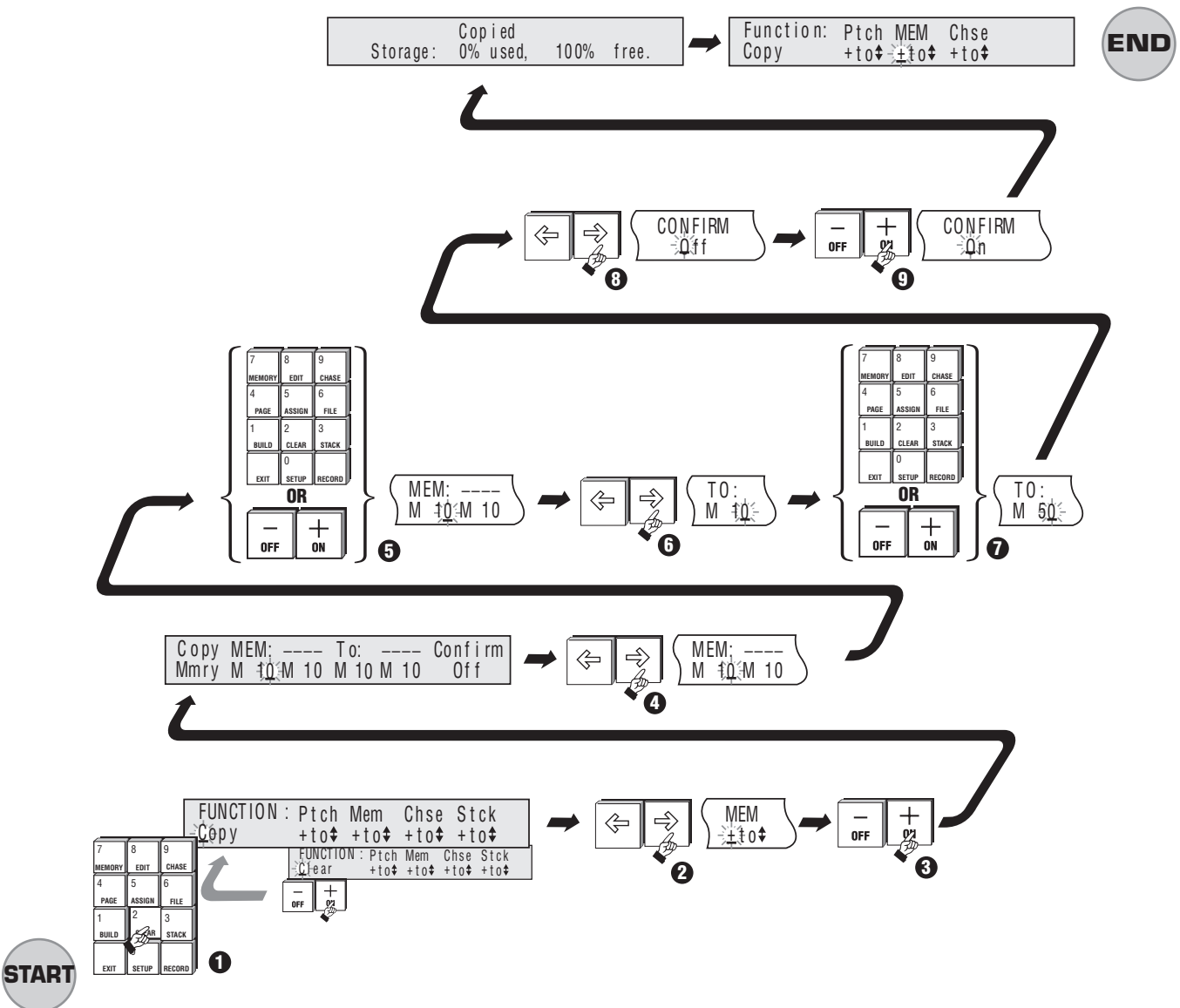

▲ 22A Copying a Memory

### 22.20 Copying a Chase

 **Diagram 22B**

- 1 Press the Clear button to open the Clear/Copy menu.

**Note:** Move the cursor to the **FUNCTION:** field and press the + (On) button to toggle the field from Copy to Clear if necessary.

- 2 Move the cursor to the CHSE (Chase) field
- 3 Press the + (On) button to open the Copy Chase menu.
- 4 Move the cursor to the CHS:(Chase:) field (the number of the Chase to be copied).
- 5 Set the Chase number to be copied.
- 6 Move the cursor to the TO: field (the number of where the chase is to go).
- 7 Set the new Chase number.
- 8 Move the cursor to the CONFIRM field.
- 9 Press the + (On) button to copy the chase.

**Example:**

*Diagram 22B shows Chase 1 being copied to Chase 10.*



### 22.30 Copying a Patch

 **Diagram 22C**

- 1 Press the Clear button to open the Clear/Copy menu.

**NOTE:** Move the cursor to the FUNCTION: field and press the + (On) button to toggle the field from Copy to Clear if necessary.

- 2 Move the cursor to the PTCH (Patch) field.
- 3 Press the + (On) button to open the Copy Patch menu.
- 4 Move the cursor to the FROM field (the Patch table to be copied).
- 5 Set the Patch table to be copied.

**NOTE:** The maximum number of Patches is three (3).

- 6 Move the cursor to the TO: field (the new Patch table to be copied to).
- 7 Set the Patch table number.
- 8 Move the cursor to the CONFIRM field.
- 9 Press the + (On) button to copy the Patch.

**Example:**

*Diagram 22C shows Patch 1 being copied to Patch 2.*

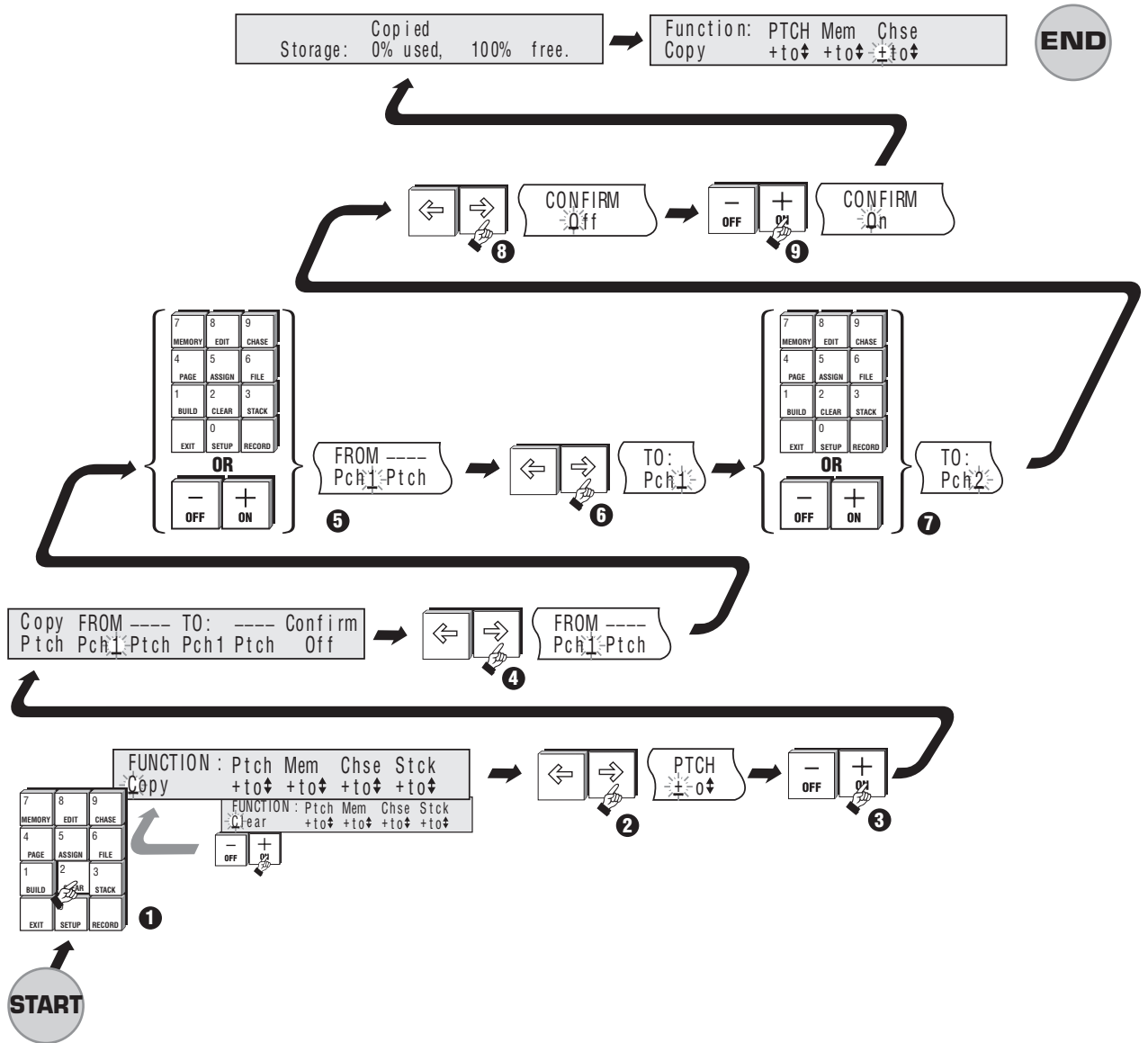

▲ 22C Copying a Patch

## 23.00 Resetting the Console

Reset is used to reset the console and optionally clear all data including Memories, Chases, Patches and the Password. Reset can be used to quickly erase all data that has been recorded in an Event.

**NOTE:** It is recommended that a Deep Clear be performed each time a new show is to be recorded.

### 23.10 To Reset the Console

 **Diagram 23A**

Turn power switch off first before resetting the console, then follow the steps below to reset the console:

- 1 Hold the DBO, ADD/SOLO MASTER and HOLD buttons down while turning power on to the console.
- 2 The menu illustrated in diagram 23A appears on the right hand side LCD window.
- 3 Move the cursor to the CONSOLE field.
- 4 Press the + (On) button.
- 5 Press the RECORD button to confirm the console Reset.
- 6 If required, enter a Password (up to 6 characters) using the flash buttons.
- 7 If no Password is required press Exit. All data is now cleared from the console and all settings revert to the factory set defaults.

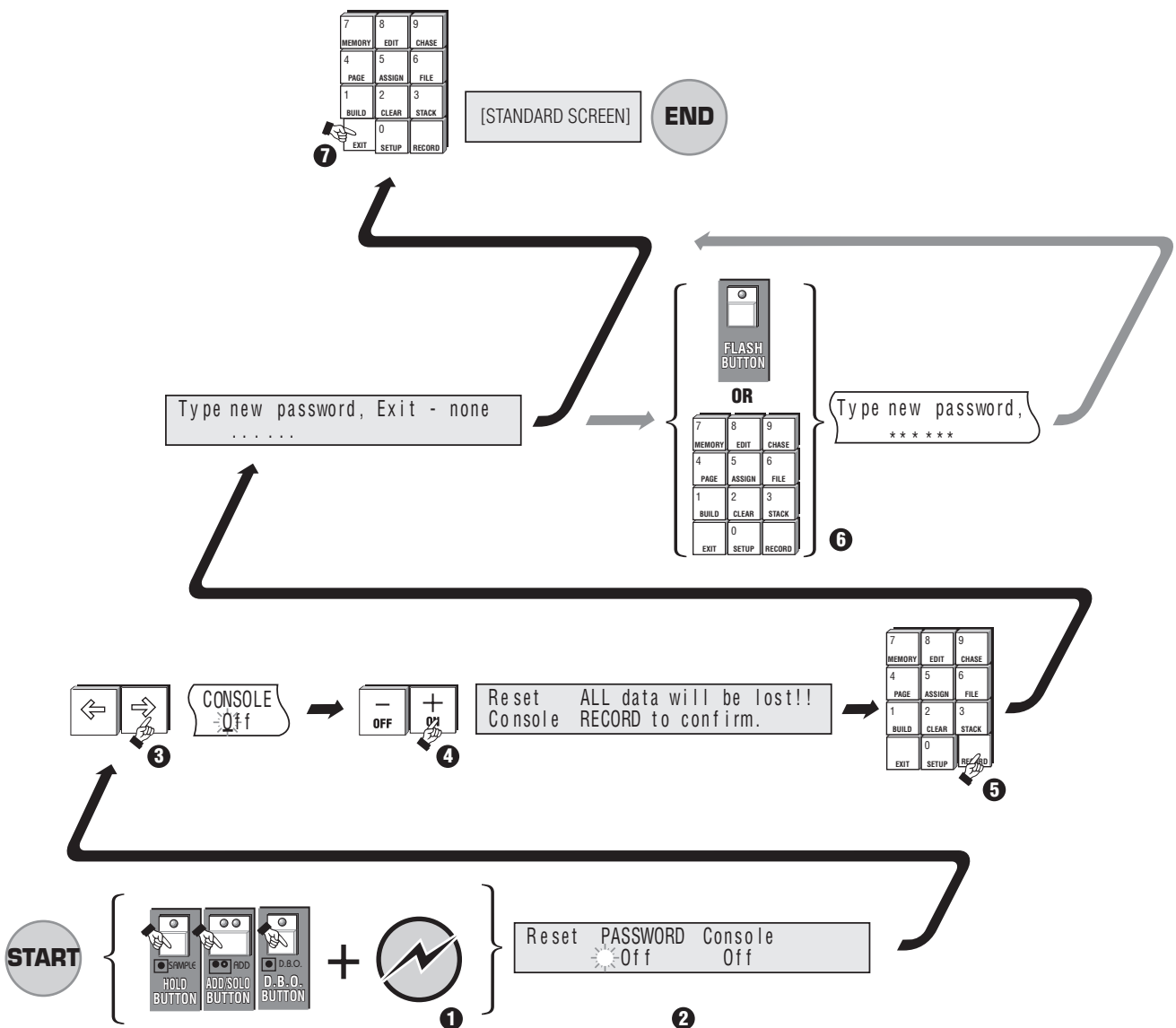

▲ 23A Resetting the Console

### 24.00 Connecting a Slave Console

A second console (Jands Event, ESP II or Stage 12/24) can be connected to provide extra Preset faders when the main console is set to wide mode (see [Section 5.00](#)).

To do this the main console must be set to Master operation and the other console must be set to Slave operation.

#### 24.10 To Set an Event Console as a Master

1. Press the Setup button to open the Setup Menu.

**NOTE:** The master desk has to be set into wide mode first.

2. Move the cursor to the DESK field and press the + (On) button to open the Set Desk menu.
3. Move the cursor to the LINK field and press the + (On) button to open the Set Link menu.
4. Move the cursor to the MASTER field and press the + (On) button to change the field to ON.
5. The StartCh# (Start Channel Number) field now appears. This field sets the channel number that the first Preset fader on the slave console will control. The field defaults to one greater than the number of Preset Flash buttons.
6. Move the cursor to the CONFIRM field and press the + (On) button.

**TIP:** If you want to use the Slave console to control a different range of channels, change the StartCh# field to the preferred setting.

#### 24.20 To Set an Event Console as a Slave

1. Press the Setup button to open the Setup menu.
2. Move the cursor to the DESK field and press the + (On) button to open the Set Desk menu.
3. Move the cursor to the LINK field and press the + (On) button to open the Set Desk Link menu.
4. Move the cursor to the SLAVE field and press the + (On) button to change the field to ON.
5. Press the Exit button to cancel Slave operation.

**NOTE:** The mimic LEDs do not function when in slave mode.

## 25.00 Event LCD Displays

### 25.10 LCD Control

The two LCDs located on the front panel of the Event can be configured to suit different lighting conditions and viewing angles.

1. Press the Setup button to open the Setup menu.
2. Move the cursor to the DESK field and press the + (On) button to open the Set Desk menu.
3. Move the cursor to the DISPLAY field and press the + (On) button to open the Setup Display menu.
4. Move the cursor to the LCDS (LCDs) field and press the + (On) button to open the Setup LCDs menu.
5. The menu includes three fields:

\* **Bright[0 - 15]**

*At 0 there is minimal backlighting of the LCDs. At 15 maximum backlighting is provided.*

\* **Contrast [0 - 15]**

*Higher contrast settings tend to make the LCDs more legible from lower viewing angles.*

\* **Cursor [Block / Line]**

*Sets the cursor style in the LCDs. Generally a block cursor is easier to locate.*

### 26.00 Setting the Intensity of the Desklights

The Event can be fitted with optional gooseneck type desklights. The brightness of the lights can be set in the Setup Desk Display menu.

1. Press the Setup button to open the Setup menu.
2. Move the cursor to the DESK field and press the + (On) button to open the Set Desk menu.
3. Move the cursor to the DISPLAY field and press the + (On) button to open the Setup Display menu.
4. Move the cursor to the LAMP field and adjust the setting between 0 and FF using the + (On)/- (Off) buttons or the numeric keypad.
5. Press the Exit key to close the menu.

**NOTE:** The desk lights can NOT be dimmed off.

## 27.00 Using MIDI to Control the Event

The Musical Instrument Digital Interface (MIDI) is a well established standard which allows communication between suitably equipped devices. The Event is equipped with a MIDI input socket which is used to allow MIDI control of various console functions.

### 27.10 To select the MIDI menu:

1. Press the Setup button to open the Setup menu.
2. Move the cursor to the DESK field and press the + (On) button to open the Set Desk menu.
3. Move the cursor to the EXTN (External) field and press the + (On) button to open the Setup External menu.
4. Move the cursor to the MIDI field and press the the + (On) button to open the Setup MIDI menu. The MIDI menu contains five fields:
  - \* **MIDI:** The MIDI field must be turned ON for MIDI to be used. The MIDI interface can be configured (using the other menu fields) to suit your requirements and then turned On and Off as required.
  - \* **MIDI-Ch (Channel):** MIDI information can be broadcast on any of 16 channels. To set which channel the Event will 'respond' to, enter a value between 1 and 16.
  - \* **Prog (MIDI Program change messages):** The Event responds to MIDI Program change information. Program change messages can be used to activate any of the Memories from 1 to 128 inclusive. To use the Program change messages turn PROG field ON.

**NOTE:** When Program is turned ON Assign Masters 23 & 24 on an Event Plus are fixed as a Crossfade STACK and Memories are played back through those faders.

#### *Example:*

*If MIDI Program Change message 25 is received, Memory 25 will play back on Assign Masters 23 & 24 using the fade times set for that Memory.*

- \* **Assign (Assign fader number):** The Assign field sets which Flash button will be triggered by the Note set in the NOTE field. Assign 1 is on the extreme left hand side of the Assign Masters. Each Assign Master can be set to respond to a different Note, to do this step through the ASSIGN field setting each fader to the desired Note. The ASSIGN/NOTE fields update immediately and there is no need to press Record to save changes.
  - \* **Note (MIDI Note message):** MIDI allows for 128 Note messages to be broadcast. The NOTE field is used to set which of the 128 Notes will be associated with each of the 12 Assign Masters. Whenever a Note that has been specified in this menu is received it will be equivalent to pressing the associated Assign Flash button.
5. First set the ASSIGN field from 1 to 12.
  6. Set the NOTE field from 1 through 128 - corresponding to the 128 MIDI Notes.

**TIP:** If you do not want to use MIDI NOTE messages on a particular Assign Master, set the NOTE field to zero (displayed as OFF). To set the field to off, enter a zero or double click on the OFF (-) button.

## 28.00 Connecting an External Monitor to the Event - Option

The Video Display MCard (VDU) option allows the user to display console data on an IBM-type video monitor, and to save and restore console data on a removable memory card. Two types of VDU options support the most common VDU monitors available as follows:

- \* EGA / CGA / Monochrome (obsolete)
- \* VGA

As of January 1995, the EGA / CGA / Monochrome option panels are obsolete as these monitor types are no longer manufactured. VGA monitors are available from computer stores. Regardless of the monitor type, the information displayed is still the same.

Memory Cards are available from Jands dealers.

The Video/MCard option can be used with all other Event option panels, including the FDD option.

### 28.10 Installation

Follow the instructions in the upgrade kit (if used), making sure you follow the correct instructions for your console. Put the old parts to one side so that if the upgrade does not work correctly, the original parts can be replaced to restore console operation.

When the installation is complete, check that the console operates normally. If the software has been changed then a Deep Clear (reset) must be performed as per Section 23 of the user manual.

### 28.20 Operation

Use the SETUP/DESK/DISPLAY menu to adjust the VIDEO option to select the type of video monitor/option panel combination that has been installed.

**NOTE:** Damage can occur to a video monitor if it is not set to the correct video type.

Once installed, the VDU shows console data at all times. When in no menu (ie. no keypad button pressed), use the cursor keys to select between either the stage display or a recorded memory/chase list. Pressing a function key activates a screen, eg. when the FILE button is pressed, the VDU changes to show a display of the file contents as recorded.

### 28.30 MCard

See Section 20 of the user manual for information on using the MCard option.

## 29.00 Analogue Output - Option

As an option on the Event console Socapex output connections can be fitted. These Socket kits are available from Jands dealers.

Up to eight connectors can be fitted to the console to provide up to 240 channels of analogue dimmer control.

Each Socket provides 30 x outputs 10V(+) / Max. Capacity: 10mA.

**NOTE:** See installation information provided with this option.

# 30. 00 Floppy Disc Drive - Option

## 30.10 Introduction

The Floppy Disk Drive (FDD) option allows the user to save and restore data on a pre-formatted IBM PC format 3.5 inch diskette. These diskettes are available from most computer stores. The FDD option can be used in conjunction with all other Event option panels, including the VDU/MCard option. Note, however, that a part change is necessary on the MCard if both the FDD and MCard options are to be used together.

**NOTE:** When fitting a FDD to an existing Event, check first with your distributor to ensure compactability.

## 30.10 Installation

Follow the instructions in the upgrade kit (if used), making sure you use the correct instruction for your console. Put the old parts to one side so that if the upgrade does not work correctly, the original parts can be replaced to restore console operation. When the installation is complete perform a Deep Clear (reset) as described in Section 23 of the user manual.

## 30.20 Operation

The FDD option functions are accessed through the SETUP/BKUP menu. In this menu there are four options:

- \* **MCard:** The MCard option functions as described in Section 20 of the user manual.
- \* **Disk:** The DISK option is used when data is to be transferred to or from the diskette. Move the cursor to the DISK option and press the +(On) button to open the Diskette control menu. Ensure a diskette has been inserted into the drive slot before this option is selected. When the diskette drive has been initialised, a menu similar to the MCard save/load menu will be opened.

**NOTE:** If no diskette is present in the disk drive when the DISK option is selected, an error message will be displayed and the DISK transfer will be aborted.

1. Move the cursor to the FILENAME option
2. Type in the name of the diskette file to be saved or loaded.
3. Move the cursor to either the SAVE or LOAD field (as appropriate)
4. Press the +(On) button to initiate transfer. Data transfer takes approximately one minute.

**NOTE:** Do not remove the diskette while the drive light is on.

- \* **Time and Date:** The TIME and DATE options are used to set the time and date of the clock on the FDD option. Once set, the time and date are added to the disk file attributes when a show is saved. These only need to be set once - the clock runs automatically after that and only needs to be reset if it becomes inaccurate.

**NOTE:** Time is displayed in 24 hour mode eg. 13:00 = 1:00pm. Use the numeric keypad or +(On)/-(Off) button to set the time.

## 30.30 Maintenance

The diskette drive mechanism is mechanical and should always be treated with care. Never allow the entry of fluids into the slot, and always ensure a diskette is in the drive when the console is moved.

# General

### 31.00 Maintenance

With care the Event console will require little or no maintenance. However, the internal battery will need to be replaced on regular basis (see [Section 32.00](#)).

#### **WARNING**

**DO NOT ALLOW THE ENTRY OF LIQUIDS OF ANY SORT INTO THE CONSOLE CHASSIS.**

If the front panel requires cleaning, wipe with a mild detergent on a damp soft cloth.

DO NOT spray liquids onto the front panel.

DO NOT use solvents for cleaning the front panel.

## **32.00 Service**

### **NOTE:**

Contact your authorised Jands Distributor for repairs or servicing.

In Australia refer all repair to an authorised Jands service agent or return the faulty unit in suitable packaging to:

**JANDS ELECTRONICS Service Department.**

**Rear, 578 Princes Highway, St Peters, NSW 2044, Australia.**

**Phone: +61 2 516 3622, Fax: +61 2 517 1045.**

### 33.00 Battery Replacement

The internal battery within the Event should be replaced every 3 years or whenever problems are experienced with the console in terms of losing memories. To replace the battery follow the procedure listed below:

#### **WARNING**

**Replacing the battery will make the console lose all stored memories. Record ALL critical information to an Mcard for floppy diskette prior to replacement.**

1. Remove base of console.
2. Desolder battery making note of polarity connections.
3. Install new battery and solder into place.
4. Install base of console.

# Appendix A

# Appendix A

## EVENT Setup Menu Structure

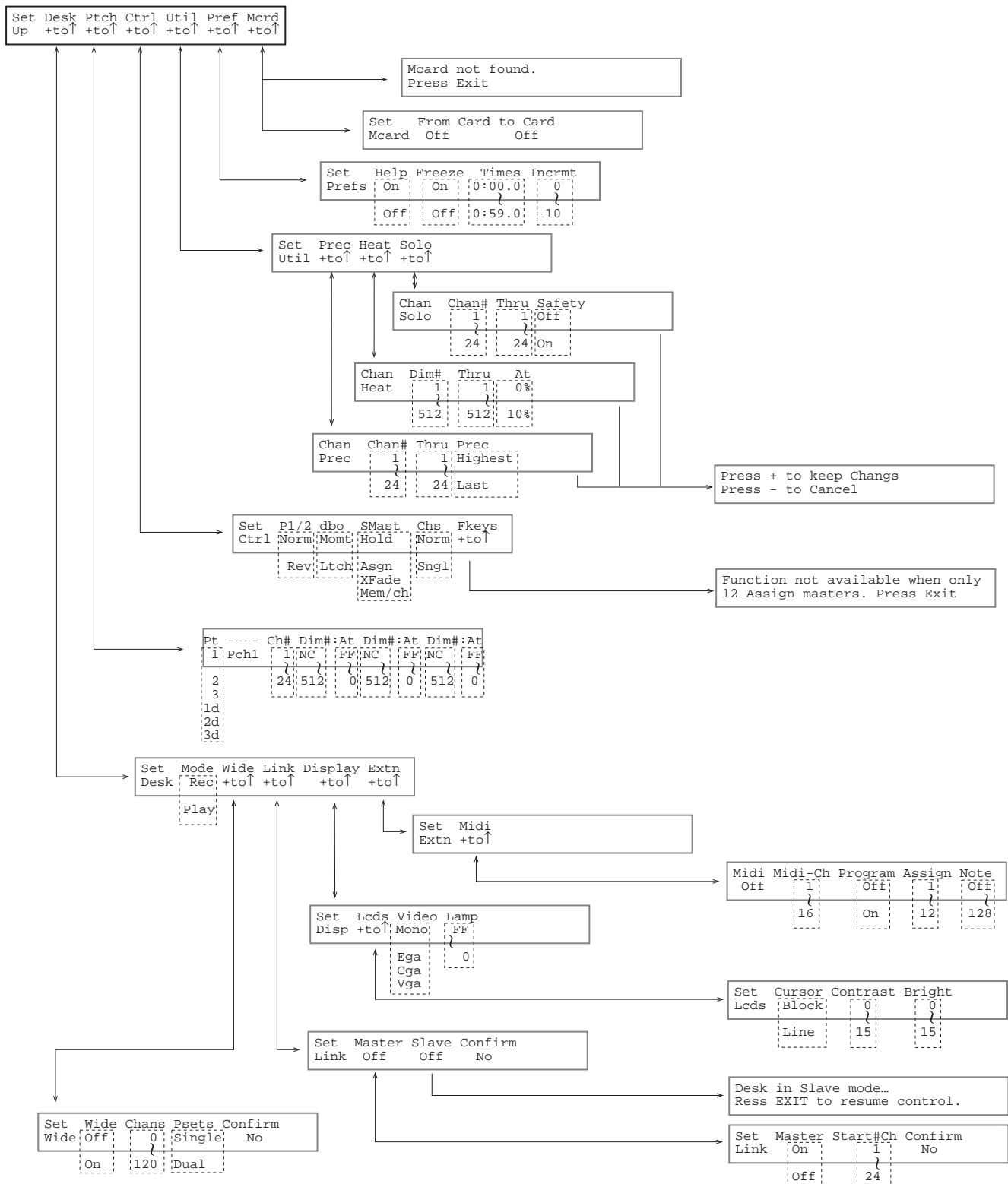

# Appendix B

# Appendix B

---

## Pin Assignments

### DMX Digital Output Socket

PIN No	Signal
1	SHIELD
2	SIGNAL -
3	SIGNAL +
4	NOT USED
5	NOT USED

Connector type: Cannon 5 pin AXR  
**RS-485 Standard USITT DMX-512 Protocol**

---

### MIDI In Socket

PIN No	Signal
1	NOT USED
2	NOT USED
3	NOT USED
4	MIDI +
5	MIDI SIGNAL

Connector type: DIN 5 pin

---

### Desklight Socket

PIN No	Signal
1	No Connection
2	Ground
3	0 - 12 volts +

Connector type: Cannon 3 pin AXR

## Desk Link Cable

To link two Event desks together connect a cable, wired as detailed below between the DMX output of the slave desk to the MIDI input on the master desk.

Cannon 5 Pin PIN No		Din 5 Pin PIN No
3	— <span style="border: 1px solid black; padding: 2px;">390R 1/4w 5%</span> —	5
2	—	4

## Power

Requirements	90 volts to 265 volts AC, 50-60 Hz
Consumption	40 watts (85 watts with analogue outputs)
Connector	IEC 3-pin inc. fuse, switch and mains filter
Fuse	2 amp M205

## MIDI Note Messages

Midi Note messages run from 0 to 127.

The Event software up to version 3.1 has the MIDI Note numbers as 1 - 128. When using the table below add 1 to each Note number.

MIDI Note	MIDI Note	MIDI Note	MIDI Note	MIDI Note	MIDI Note
36 C1	48 C2	60 C3	72 C4	84 C5	96 C6
37 C#1	49 C#2	61 C#3	73 C#4	85 C#5	97 C#6
38 D1	50 D2	62 D3	74 D4	86 D5	98 D6
39 D#1	51 D#2	63 D#3	75 D#4	87 D#5	99 D#6
40 E1	52 E2	64 E3	76 E4	88 E5	100 E6
41 F1	53 F2	65 F3	77 F4	89 F5	101 F6
42 F#1	54 F#2	66 F#3	78 F#4	90 F#5	102 F#6
43 G1	55 G2	67 G3	79 G4	91 G5	103 G6
44 G#1	56 G#2	68 G#3	80 G#4	92 G#5	104 G#6
45 A1	57 A2	69 A3	81 A4	93 A5	105 A6
46 A#1	58 A#2	70 A#3	82 A#4	94 A#5	106 A#6
47 B1	59 B2	71 B3	83 B4	95 B5	107 B6