

Chroma-Q™ M8 Plus™

User Manual



Version 1.2 June 2007

PN: 114-0501

Disclaimer

The information contained herein is offered in good faith and is believed to be accurate. However, because conditions and methods of use of our products are beyond our control, this information should not be used in substitution for customer's tests to ensure that Chroma-Q products are safe, effective, and fully satisfactory for the intended end use. Suggestions of use shall not be taken as inducements to infringe any patent. Chroma-Q sole warranty is that the product will meet the sales specifications in effect at the time of shipment. Your exclusive remedy for breach of such warranty is limited to refund of purchase price or replacement of any product shown to be other than as warranted.

Chroma-Q reserves the right to change or make alteration to devices and their functionality without notice due to our on going research and development.

The Chroma-Q M8 Plus has been designed specifically for the professional entertainment lighting industry. Regular maintenance should be performed to ensure that the products perform well in the entertainment environment.

If you experience any difficulties with any Chroma-Q products please contact your selling dealer. If your selling dealer is unable to help please contact support@chroma-q.com. If the selling dealer is unable to satisfy your servicing needs, please contact the following, for full factory service:

Outside North America:

Tel: +44 (0)1494 446000
Fax: +44 (0)1494 461024
support@chroma-q.com

North America:

Tel: 416-255-9494
Fax: 416-255-3514
support@chroma-q.com

For further information please visit the Chroma-Q website at www.chroma-q.com.

Chroma-Q is a trademark, for more information on this visit www.chroma-q.com/trademarks.

The rights and ownership of all trademarks are recognised.

Table of Contents

1. Product Overview	3
2. Operation	4
2.1 Unpacking the unit	4
2.2 Control and power cables	4
2.3 Gel Loading and Replacement	5
2.4 Mounting the unit	7
2.5 Operating the unit	7
2.6 Modes of operation	8
2.7 Troubleshooting	11
2.8 Technical overview	12
2.8 Technical specifications	12
3. Maintenance and Storage	13
4. Drawings	14
4.1 Outside dimensions	14
4.2 Gel String Schematic	15
4.3 Parts Schematic	16

1. Product overview

The Chroma-Q M8 Plus takes colour changer technology to a new level. The M8 Plus is designed to give years of trouble free use, providing that they are regularly maintained and used in accordance with the instructions detailed in this manual. The M8 Plus is fully compatible with the Chroma-Q M8.

Note: This manual describes functionality available from version 2.0 of the M8 Plus software. For the latest software updates, documentation, and other information about all Chroma-Q products, please visit the Chroma-Q website at www.chroma-q.com

Safety information

Warning! This product is for professional use only. It is not for household use.

Read this manual before powering or installing the colour changer, follow the safety precautions listed below and observe all warnings in this manual and printed on the accessory. If you have questions about how to operate the colour changer safely, please contact your Chroma-Q dealer or e-mail support@chroma-q.com.

Protection from electric shock

- Do not expose the colour changer to rain or moisture
- Refer the service operation not described in this manual to a qualified technician

Protection from burns and fire

- Keep flammable materials well away from the colour changer
- Provide a minimum clearance of 0.1 meters (4 inches) around air vents
- Do not modify fixture accessory or install other than genuine Chroma-Q parts

Protection from injury due to falls

- When mounting the colour changer, verify that the fixture frame can hold the weight of the device
- Verify that all external covers and rigging hardware are securely fastened and use the supplied means of secondary attachment, the safety cable.
- Block access below the work area whenever installing or removing the colour changer

The M8 Plus is designed to operate on the ANSI E1.11 USITT DMX512-A protocol. This multiplexed serial data system allows for the individual addressing of multiple units on one data cabling system. The unit utilises one or two DMX channels depending on the mode of operation.

The unit is addressed by using the three embossed push button switches and LED display found on the user interface panel located on the bottom of the body. These switches are also used to select cooling fan speed, 'gel saving' mode, scrolling speed, display lighting, remote operation, and reset.

Another feature of the user interface panel is a diagnostic section on the LED display showing Power, DMX signal and signal strength.

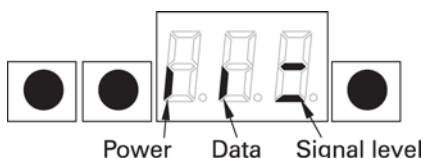

The first vertical bar indicates that there is power (24VDC).
The second vertical bar indicates that there is data (DMX).
The horizontal bars indicate the data (DMX) signal level.
The signal level changes during normal operation of the unit. 1st bar = 25%, 2nd bar = 50% and 3rd bar = 75%

Note: Full menu description on page 8.

The M8 Plus is supplied power and control signals by means of two 4-pin XLR style connectors on the rear panel, allowing multiple units to be 'daisy-chained' into the same line of cabling. Patching the output from the last unit back into the power supply will terminate the DMX for each chain line and ensure even power voltage across all colour changers in that chain.

Note: The quantity of M8 Plus colour changers, and maximum cable length per power supply output is dependant upon the size of PSU / Splitterbox used. (See later in this manual for details.)

The rear of the Chroma-Q M8 Plus is designed to accept eight point standard mounting bracket for 8 light blinder fixtures.

2. Operation

- 2.1 Unpacking the unit
- 2.2 Control and power cables
- 2.3 Mounting the unit
- 2.4 Operating the unit
- 2.5 Modes of operation
- 2.6 Troubleshooting
- 2.7 Technical overview
- 2.8 Technical specifications

2.1 Unpacking the unit

The M8 Plus package includes 1 unit M8 Plus with safety chain.

2.2 Control and power cables

The M8 Plus utilises an XLR 4-pin cable system. This is used for power and data transfer. Pins 2 and 3 are for ANSI E1.11 USITT DMX 512-A data. Pins 1(-) and 4(+) are for 24VDC power.

Damage will occur if power connections short to data or ground/shield connections. When assembling XLR 4-pin cables, heat shrink should be used on each individual pin to prevent short circuits (Tourflex Ultra Datasafe P&D cable recommended). See diagram below.

Note: It is very important to ensure that the drain wire from the cable shield is connected to both XLR connector cases.

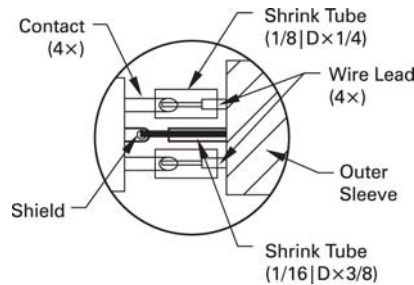

Detail of connector wiring

The correct wiring between male and female connectors is 'one to one'.

Pin #	Pin #	Minimum Cable size
1	Ground (-ve)	2.50mm ² (14 AWG)
2	Control data minus (-)	0.35mm ² (22 AWG)
3	Control data plus (+)	0.35mm ² (22AWG)
4	24V DC (+ve)	2.50mm ² (14 AWG)
Chassis	Cable shield/drain wire	0.25mm ² (24 AWG)

Note: Total cable length should not exceed 60m / 200 ft with return line.

Connections:

Correct cabling procedure and connection of the units to the power supply will increase signal strength and prevent malfunction. Please follow these basic rules.

- a) Use the correct type and gauge of cable and connectors. (Tourflex Ultra Datasafe P&D cable recommended).
- b) Keep cable runs as short as possible to reduce line loss.

- c) It is recommended to use a return cable for each run. This will ensure balanced DC power to all units, where the line is correctly terminated, and all units receive power if one link of the chain is faulty.

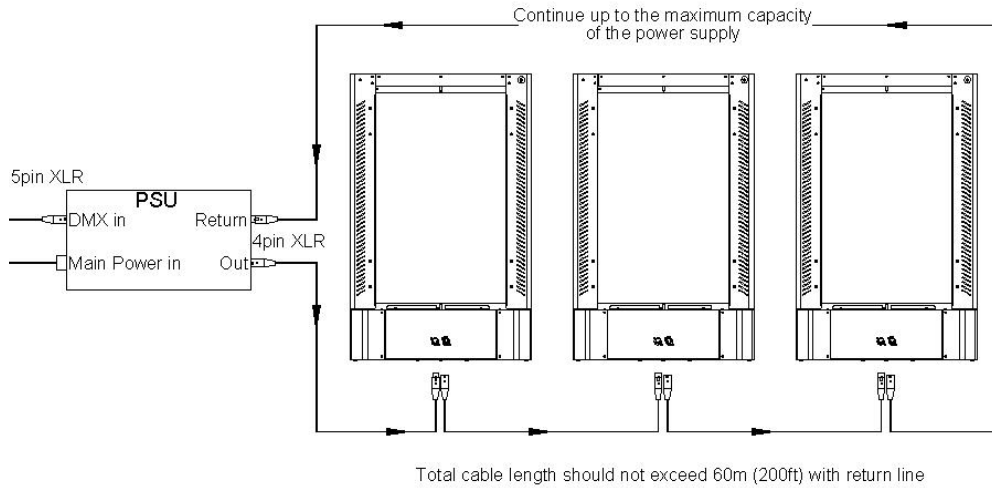

Note: Standard signal input is a male XLR chassis connector and output is a female XLR chassis connector.

Warning! Always ensure that safety wire is connected before final inspection.

2.3 Gel Loading and Replacement

Changing the gel strings is easy, but it may take some time and practice to accomplish, if the user is not familiar with these types of colour changers. There are two methods of loading gel strings on the M8 Plus, manually or using the power assisted loading method ("PAL" Load).

Note: It is suggested that new users of this product load the gel strings by the manual method until they become familiar with the units.

Replacing the gel string (Manual Mode):
(See also the drawing section of this manual).

Gel Description

The standard gel string consists of a head, gel frames and a tail. Pro Color HT+, Rosco Supergel and GAMcolor are the recommended media. The head and tail are taped to the Take-Up Reels (TUR).

Gel String Dimensions and Assembly

To join a leader, tail and gel together, a high temperature, clear gel tape is recommended (see Product Ordering List on page 14).

The completed string should look like this:

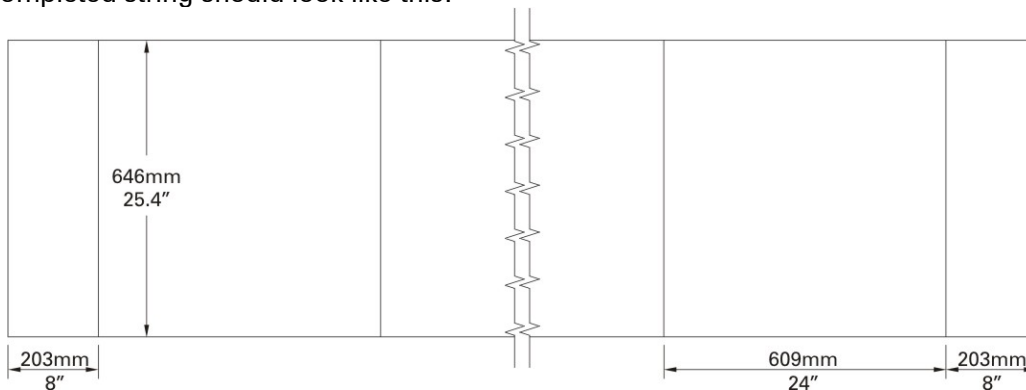

Note: A range of completed custom gel strings are available upon request. Contact the selling dealer for details. When ordering gel strings please state the Chroma-Q model the gel string will be built for.

Warning! Because of the gel saver mode the M8 Plus gel strings have a longer frame. A GL gel string should be used to maximise the effect of this mode.

Manual loading for the M8 Plus

(See image below when installing gel string).

1. Place the unit on a flat surface with motor/fan/electronics on your right-hand side (assuming you're loading from 'tail' end of the string, reverse if starting from the 'leader' end of the string).
2. Tape the top and bottom edge of the tail end of the gel string to the Take Up Reel (TUR). Follow the centre line guide scribed on the TUR.
3. Wind the gel string onto the TUR manually and thereafter, gently pull the string towards you to tighten the roll.
4. Rotate the unit to position motor/fan/electronics on your left-hand side.
5. Tape the top and bottom edge of the leader end of the gel string to the TUR. Follow centre line guide scribed on the TUR.
6. Plug in the colour changer, and check that it goes through the initialisation sequence correctly. Check that the gel runs smoothly and does not bind up on the TUR's.
7. Run a test sequence to allow the gel string to 'bed' in. The unit does not have to be attached to a lighting fixture to perform this operation. It is recommended that this sequence is run for a few minutes (or 3 to 4 times, end-to-end).

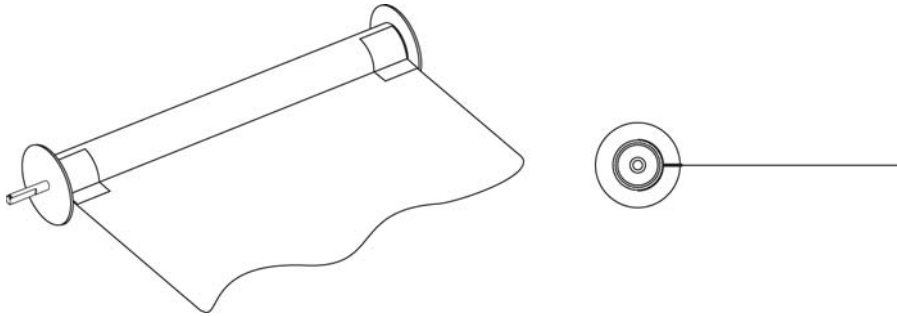

Notes:

- For normal operation, the start (leader) of the gel string is on the left-side TUR and the end (tail) of the string on the right-side TUR, when viewed from the front of the unit.
- Do not power lights without powering up the colour changer first. The fan must be running in order to protect gels from premature failure.
- High fan speed is recommended on all lighting fixtures of 2000 Watts and above.
- Poorly optimised light bulbs in some fixtures may result in premature gel failure.

Power Assisted Loading ('PAL-Load')

(See also: 'Operating the unit' and drawing sections of this manual).

'PAL'-Load controls the direction of the Take-Up Reels (TUR) with the UP and DOWN button. In this mode the user can wind and unwind the gel string using the colour changer motor. With practice this will allow for speedier loading and unload of gel strings.

1. Place the unit on a flat surface with motor/fan/electronics on your right-hand side (assuming you are loading from 'tail' end of the string, reverse if starting from the 'leader' end of the string).
2. Tape the top and bottom edge of the tail end of the gel string to the Take Up Reel (TUR). Follow the centre line guide scribed on the TUR.
3. Apply power to the unit while holding down the MENU button. The display will show the legend PAL
4. Press and hold UP until gel string is wound onto TUR.



5. Rotate the unit to position motor/fan/electronics on your left-hand side.
6. Tape the top and bottom edge of the leader end of the gel string to the other TUR. Follow centre line guide scribed on the TUR.
7. Allow the unit to self-calibrate by pressing the UP and DOWN buttons simultaneously, or by unplugging and re-plugging the colour changer.
8. Run a test sequence to allow the gel string to 'bed' in. The unit does not have to be attached to a lighting fixture to perform this operation. It is recommended that this sequence is run for a few minutes (or 3 to 4 times, end-to-end).

2.4 Mounting the unit

(See section 4.3)

The M8 Plus is designed to mount in a variety positions but with the base of the unit below the fixture. Do not mount in an inverted position with the base of the unit above the fixture, as the rising heat from the fixture may cause the gel string damage.

The rear of the M8 Plus has eight reinforced mounting stands with an M4 sleeved thread inserted. The spacing of these stands is set to accommodate standard 8-Lites Blinder mounting bracket, Chroma-Q part number CHMP80.

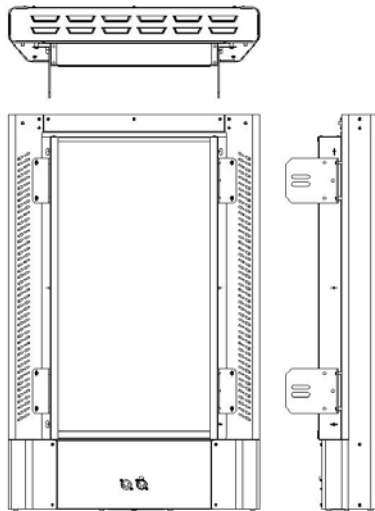

Safety Wire

The M8 Plus should always be used with the safety wire provided.

2.5 Operating the unit

All the unit functions are accessed using the LED display and the three push-button switches on the bottom panel.

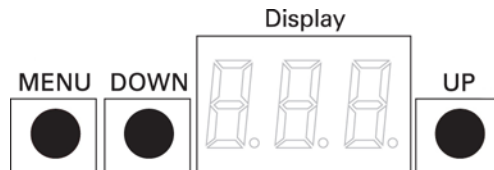

Control	Function
MENU Button	Mode access and record
DOWN Button	Decreases (-) the mode level or value
UP Button	Increases (+) the mode level or value
3 digit display	Displays mode, monitor or blank display

Push button operation:

The MENU button is used to scroll through the different modes of operation, and the UP or DOWN buttons used to select the level, or value, in that mode.

If any mode or value is changed the display will begin flashing;

- To restore the previous value, press and release the MENU
- To record the change depress and hold the MENU button for 2 seconds or until last character stops flashing

Display operation:

Power-up Display

On power-up, the unit will go through its self-calibration mode and the display will show the units software version. (i.e. 1.0.0)



After the self-calibration finishes, the display will double check and show the DMX address mode. (i.e. 001)



Monitor Display

If left undisturbed for 5-7 seconds, the display will revert to 'Monitor Mode'

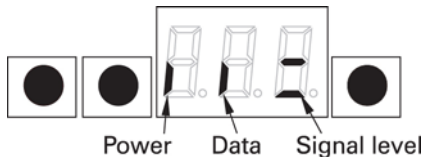

The first vertical bar indicates that there is power (24VDC).
The second vertical bar indicates that there is data (DMX).
The horizontal bars indicate the data (DMX) signal level.
The signal level changes during normal operation of the unit. 1st bar = 25%, 2nd bar = 50% and 3rd bar = 75%

Display Flip

The display-viewing angle can be flipped through 180° by pressing the MENU and DOWN button simultaneously.

Display Mode

The display can be set to auto-blackout after 12 seconds. This is selected through the mode menu under 'dP', where dP0 is OFF and dP1 is ON.

Reset

If the MENU and the UP button are pressed and held for 1 second, the unit will reset to the factory default settings. This feature is particularly useful when the units are used in many different configurations or shows.

The reset function is also available through 'Remote Operation' (See later in this section)

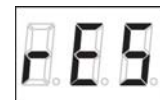

2.6 Modes of operation

Notes:

- The MENU button is used to scroll through the different modes of operation, and the UP or DOWN buttons used to select the level or value, in that mode.
- If any mode or value is changed, the display will flash until the MENU button is pushed and held for 2 seconds to record the change.
- When the MENU button is held for 2 seconds, the unit will save the change(s) and these 'user defaults' will take precedence immediately.
- If MENU button is not held for 2 seconds to previous value will be displayed
- The unit will not save any change(s) made by remote control after the next power cycle.

DMX addressing mode

This mode is used to set DMX data address of the unit. The unit uses one or two DMX channels depending which mode it is operating.

The display shows the current DMX address (between 1-512).

To alter the address, press UP or DOWN button once to increment or decrement the value; hold down the UP or DOWN for fast increments and decrements of the value.

(See also: 'Remote Operation' later in this section.)

Fan speed mode (Fn)

This mode is used to set the gel cooling-fan speed of the unit. This feature can be used in environments where a lower noise level is required, although this may decrease gel string life.

The display shows the current gel cooling fan speed. There are four fan speeds, 1 is the slowest and 4 is the fastest.

Press UP or DOWN once to increment or decrement the value.

(See also: 'Remote Operation' later in this section.)

Gel saver mode (GL)

Gel-saver mode is used to switch the gel-saving mode on or off. This feature slowly moves the chosen gel frame back and forward slightly so that the heat build-up is dissipated over a larger area, extending the life of the gel string. Press the UP or DOWN buttons once to switch between On (1) and Off (0) (the default is Off). Press hold MENU for 2 seconds to save the new setting.

This feature is also available via DMX (see "Remote operation" section of this manual).

The appropriate gel string should be installed to maximise the benefit of this mode.

Speed mode (SP)

This mode is used to set the scrolling speed of the unit. This feature allows the gel string to move at a higher speed, for more rapid changes. Use of this high speed will generate more noise from the unit.

Press the UP or DOWN buttons once to switch between Standard (1) and Fast (2) (the default is Standard). Press and hold MENU for 2 seconds to save the new setting.

This feature is also available via DMX (see "Remote operation" section of this manual).

Display mode (dP)

This mode is a two step feature set with the UP and DOWN button, on (1) and off (0). Default is off (0). When set to dP1 the display will change to diagnostic mode after 6 seconds. When set to dP0 the display will change to the diagnostic mode in 6 seconds, then clear in another 6 seconds, making 12 seconds till auto-blackout. The display will return to diagnostic mode with the first button press and will do the action of the second press.

Remote Operation mode (ro)



This mode is used to switch between the different remote operation modes in the unit. The use of these different modes greatly enhances the versatility of the unit by giving the user remote control of some functions.

There are three remote operation modes:









Mode 1 =	Single-channel DMX operation. The channel controls the colour selection.	
Mode 2 =	Dual-channel DMX operation. The 1 st channel controls the colour selection. The 2 nd channel controls the fan speed; 0-24% = Fn 4(fast), 25-49% = Fn3, 50-74% = Fn2, 75-100% = Fn1 (slow).	
Mode 3 =	Dual-channel DMX operation. The 1 st channel controls the colour selection. The 2 nd channel controls the units other functions.	
These functions initialise two seconds after the channel level is entered.	Ch. 2 Level	Feature
	0-5%	= No feature
	6-15%	= Fan off
	16-25%	= Fan speed 1 (slowest)
	26-35%	= Fan speed 2
	36-45%	= Fan speed 3
	46-55%	= Fan speed 4 (fastest)
	56-65%	= Gel Saver off
	66-75%	= Gel Saver on
	76-85%	= Motor speed normal, see Speed mode (SP)
	86-95%	= Motor speed fast, see Speed mode (SP)
	96-99%	= Reset (reset to user defaults)

The display shows the current Remote Operation mode of the unit. Press UP or DOWN to increment or decrement the mode setting.

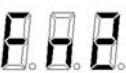
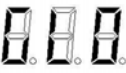
Summary of control functions:

Operation or Mode	Operation Description	Actions required	Display
Power-Up	Software version shown on the unit(s) at power-up.	This shows the software version while the unit is self-calibrating, before displaying the 'Monitor Mode'.	
reSet	This will reset the unit to the default settings.	While holding down MENU and UP button for 1 second.	
Power Assisted Loading ('PAL-Load')	Used to load a gel-string into the unit.	Hold down the MENU button during power-up. Pressing the UP button will advance the fixed TUR. Pressing the DOWN button will advance the spring TUR. Press both DOWN & UP buttons, or cycle the power, to re-calibrate.	
See also, gel loading instructions			

Modes (Use the MENU button to scroll through these modes)

DMX addressing Mode	Used to set the units DMX data address	The display shows DMX address (1-512). Press DOWN or UP <u>once</u> to increment or decrement the value, <u>hold down</u> the DOWN or UP for fast increment or decrement.	
See also, DMX addressing instructions			
Fan speed Mode	Used to set the fan speed of the unit.	The display shows the current gel cooling fan speed. There are four fan speeds, 1 is the slowest and 4 is the fastest. Press UP or DOWN <u>once</u> to increment or decrement the value,	 
See also, fan speed instructions			
'Gel Saver' Mode	Switches on/off the gel saving mode.	The display shows the current gel saver mode. Press UP or DOWN <u>once</u> to switch between on (1) and off (0).	 
See also, gel saver mode instructions			
'speed' Mode	Used to set the scrolling speed of the unit.	The display shows the current gel scrolling speed. There are two scrolling speeds. 1 is the slowest, 2 is the fastest. Press UP or DOWN <u>once</u> to increment or decrement the value,	 
See also, gel scroll speed instructions			
'disPlay' Mode	Switches on/off the display	Switches the display on or off. Display will re-activate when any button is pressed. Press UP or DOWN to switch between on (1) and off (0).	 
(See also, display mode instructions)			

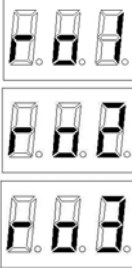
'remote-operation'	Mode1 =single DMX channel operation. Mode 2 = Dual DMX channel operation (Colour/Fan speed) Mode 3 = Dual DMX channel operation (Colour/Function)	The display shows the current DMX mode of the unit. There are three DMX modes Press UP or DOWN button to increment or decrement the mode setting,	
--------------------	---	--	---

Default Settings:

Factory default settings

If the MENU and the UP button are pressed and held for 1 second, the unit will reset to the factory default settings. This feature is particularly useful when the units are used in many different configurations or shows.



The reset function is also available through 'Remote Operation'

The Factory default settings put the unit in its manufacturer operating mode.

- Fan speed = 4 (fast)
- Gel saver = 0 (off)
- Gel speed = 1 (slow)
- Display = 1 (on)
- Remote operation = 1 (normal)
- Display flip = standard

'User' default settings

Each time the MENU button is pressed and held for 2 seconds, the unit will save that change and these 'user defaults' will take precedence immediately.

These 'User' defaults can be reset to the 'factory' defaults using the method detailed above.

2.7 Troubleshooting

The LED display aids in the troubleshooting of the M8 Plus system. These indicators are located on the bottom of each unit.

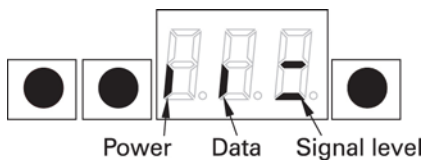

The first vertical bar indicates that there is power (24VDC).
 The second vertical bar indicates that there is data (DMX).
 The horizontal bars indicate the data (DMX) signal level.
 The signal level changes during normal operation of the unit. 1st bar = 25%, 2nd bar = 50% and 3rd bar = 75%

Symptom	Possible Cause	Solution
Unit does not respond to DMX control, but DMX display indicator is on.	Unit set to wrong DMX address.	Check DMX address settings.
Unit does not respond to MX, DMX display indicator is off.	Bad Cable. No DMX at Splitter/ PSU.	Check cable and DMX run from console.
Units run at different speeds.	Colour changer speed settings may be different. Cable lengths are too long. No cable return line.	Check all colour changer speed settings. Check the cable length and configuration. Ensure there is a cable return line in the system.
Units have dim display indicators and run slowly.	Cable runs too long. Too many units on one chain overloading PSU.	Check voltage levels on last unit. Should not be below 20VDC.

DMX display indicator is off on one unit.	Colour changer not connected. Bad cable. Damaged transceiver IC in the colour changer.	Check cable Send unit back for repair.
Display Indicators appear OK but gel string does not move.	Mechanical (or electrical) failure in the unit.	Turn unit on and off. Return unit for repair.
Gel burns too quickly.	Fans have failed or are too slow. Poorly optimised lamp focus in fixture. IR filter medium not fitted.	Check fans are operating. Optimise bulb focus. Replace gel strings and install IR filter.

Note: A high percentage of problems are a direct result of poor cable and corrupt DMX control signals.

2.8 Technical overview

The colour transport system employs an opto-electronic system for accurate positioning of the gel string. When the unit initially receives power it will go through a calibration sequence. The purpose of the initial calibration sequence during power up is to determine the total length of the gel string and therefore the position of the different gels.

Note: Over time the gel string may warp slightly. This may alter the positions of the gels relative to their pre-programmed DMX values and therefore some 'fine-tuning' may be required.

The motor has an optical encoder feedback system. The purpose of this is to convert motor revolutions in to electronic pulses, and also to determine which direction the motor is turning.

The electronic cards consist of three key components: L6225PD motor driver, 75176 transceiver and a processor. The L6225PD is a true digital device receiving two PWM signals to operate speed and direction. The 75176 transceiver operates in the receive configuration to convert serial protocol to a TTL level. All data relevant to the operation of the unit is stored onboard in 'flash' memory.

The majority of electronics problems are usually created by external factors such as shorted cables, etc. The 75176 transceivers are susceptible to damage if 24VDC is present on the DMX signal lines.

Routine maintenance can prevent most mechanically based problems. The motor mounting plate can be adjusted to control tension on the belt. Excessive belt tension is often the cause of noise and poor performance. Conversely, loose motor belts can cause accuracy problems.

Troubleshooting is a process of elimination. First, rule out the other field factors (i.e. faulty cables, power sources). If an electronics problem is suspected inside the unit replace the electronics card first. If accuracy problems should occur and mechanical problems have been ruled out, replace optical sensors. For technical advice and or parts, please contact your selling dealer or the offices listed in this manual.

2.9 Technical specifications

Dimensions:	538mm (w) × 846mm (h) × 118mm (d) 21.2" × 33.3" × 4.7"
Weight:	5.58kg / 12.3lb
Aperture:	479mm x 631mm / 18.8" x 24.8"
Colour media:	Pro Color HT+, Roso Supergel and GAMcolor are recommended
Gel capacity:	2 – 16 frames

Cooling:	Forced air
Cooling Speed:	4 speeds
Addressing:	Digital, via push buttons (3) and LED display
Working Voltage:	24VDC (+/- 10%)
Power consumption:	1.5 PU (see note below)
DMX protocol:	ANSI E1.11 USITT DMX 512-A
Body material:	Powder coated aluminium
Body color:	Black (white option)
Mounting plate M8 Plus:	Optional fixing
Connectors:	XLR-4 (male) in and XLR-4 (female) through
European approvals:	Complies with EU directives: EMC89/336/EEC Class A. Harmonised standards applied in order to verify compliance with directives: EN 56022:1994, EN50082-1: 1992 & EN 60950.
North American approvals:	Radiated Emissions: Complies with FCC part 15 subpart B, class A for unintentional radiators. Low Voltage Directive: Complies with CSA 22.2 950, UL 1950

Note: We use the Power Unit (PU) to simplify the load calculation on any given Chroma-Q power supply. For example a PSU-12 will supply up to 12 PU, so you can plug-in 8 M8 Plus'.



3. Maintenance and Storage

The M8 Plus should be stored in a dry and cool environment, safely secured to prevent from falling on a hard surface.

The unit may be exposed to dirty environments containing many air particles. This can lead to dust and dirt build-up in the vents and fan area. The unit should be vacuumed to remove dust and dirt. This can be done with a painters brush and vacuum. Simply brush the dust out of the vents and fan into a vacuum cleaner. DO NOT use compressed air to blow dust and dirt out of the unit.

If there is any oily residue on the body of the unit or the gel string wipe off with a damp cloth ensuring that no water enters the fan or vent area affecting the electronics.

The gel string should be inspected for wrinkling and cracking. If there are signs of wear a new gel sting should be installed.

4. Drawings

4.1 Outside dimensions

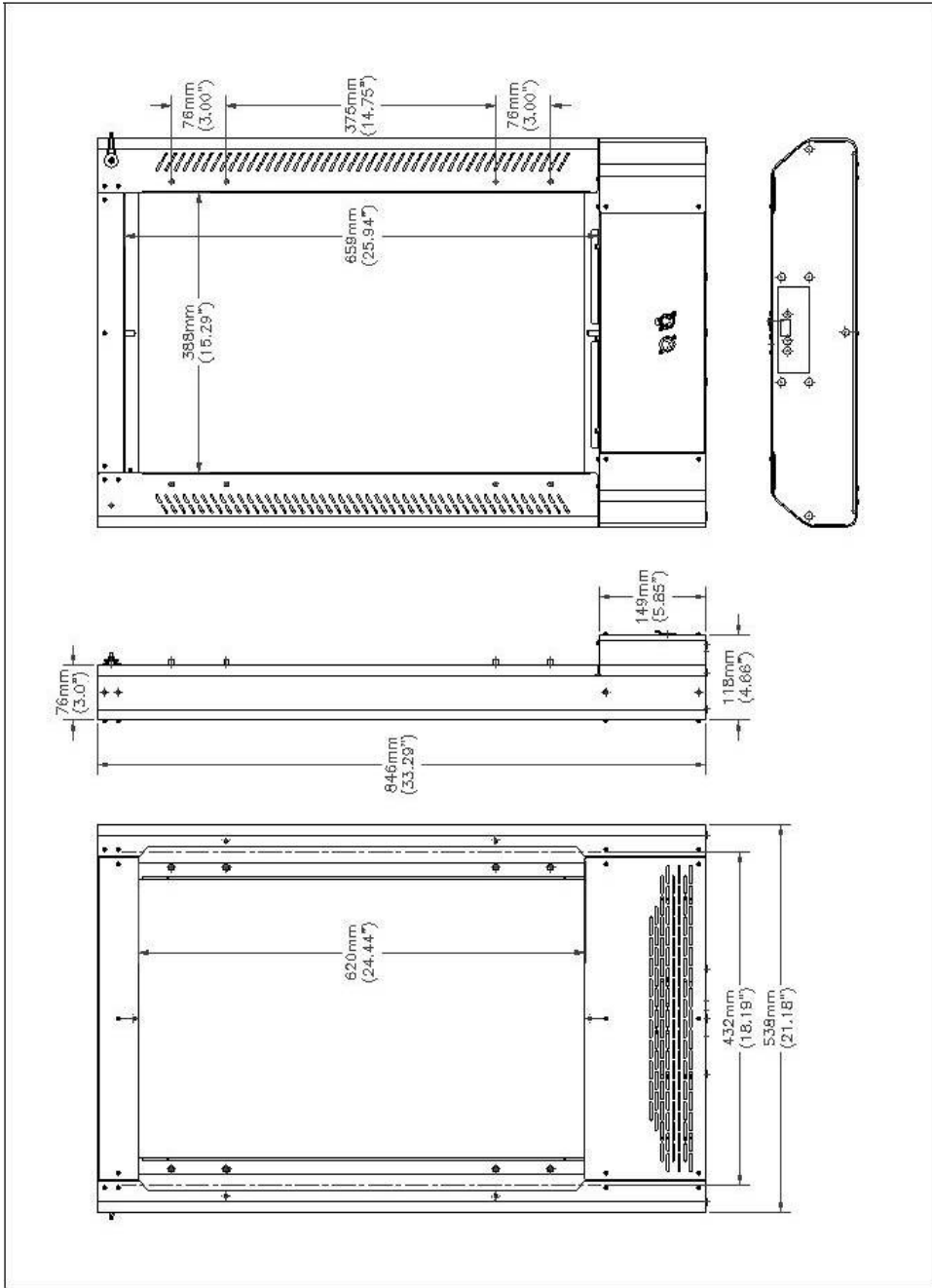

4.2 Gel String Schematic

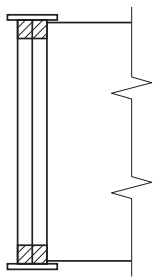
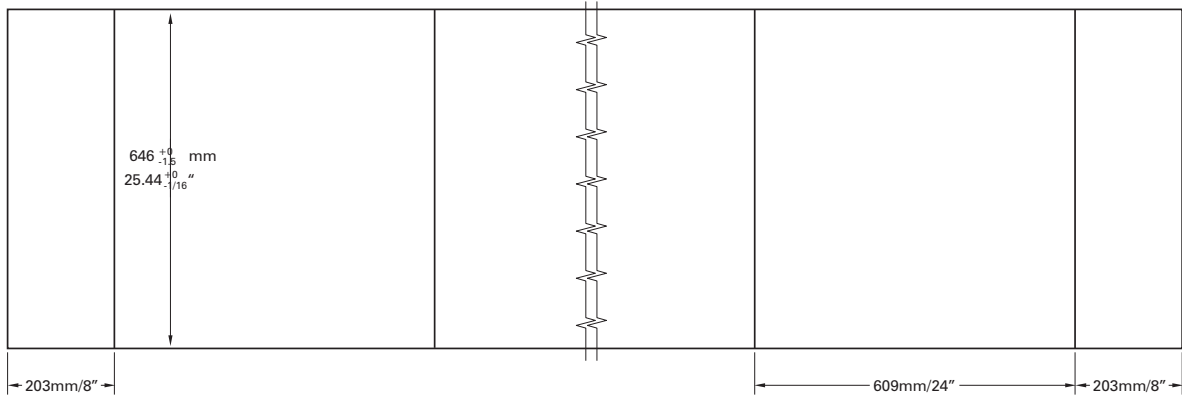

Detail of taping
the gel to the
take-up reel



Correct way of taping the
gel frames

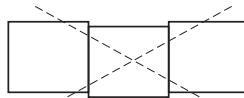

Incorrect way of taping the
gel frames

4.3 Parts Schematic

CHROMA-Q M8 PLUS

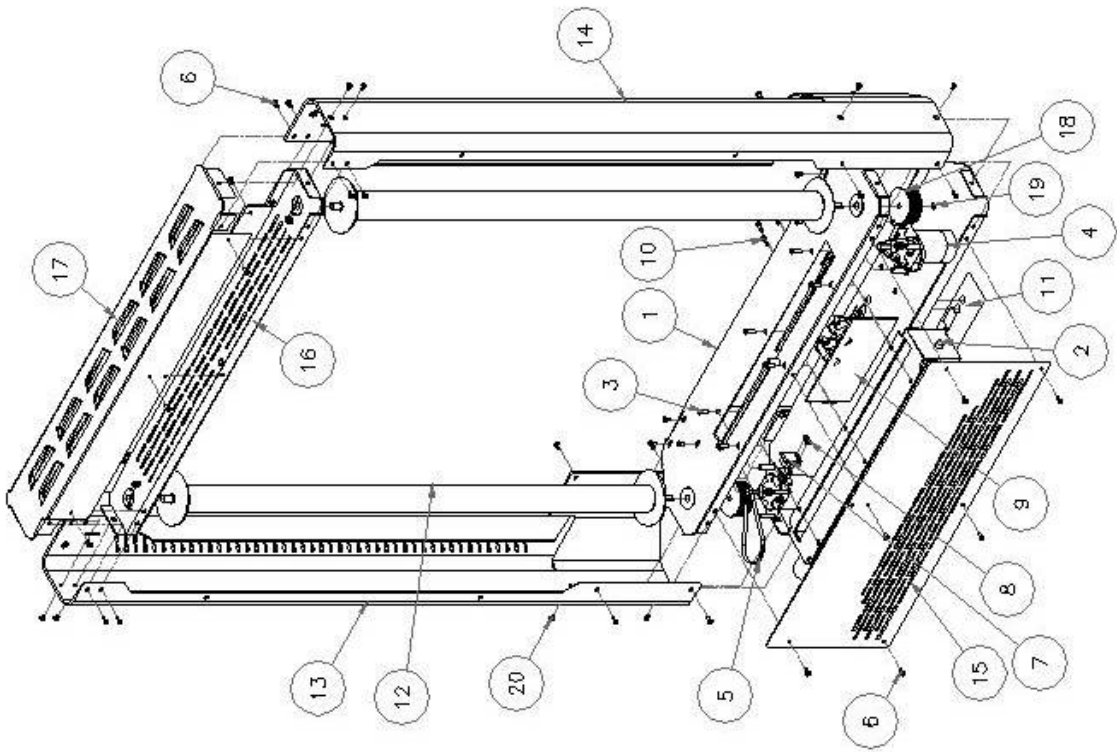

ORDER#	DESCRIPTION	PART#	QTY
COM8P-20	SCREW M3x6 FH PLPS Bik	900-0004	8
COM8P-19	RET RING EXT 6mm	900-0501	2
COM8P-18	PULLEY TIMING 48TEETH	103-0063	2
COM8P-17	CAP TOP M5 PLUS	113-0003	1
COM8P-16	S/A PLATE TOP C/W BEARINGS	113-0013	1
COM8P-15	PLATE FRONT M8 PLUS	114-0004	1
COM8P-14	SIDE RH M8 PLUS	114-0003	1
COM8P-13	SIDE LH M8 PLUS	114-0002	1
COM8P-12	TAKE-UP REEL M8 PLUS	114-0007	2
COM8P-11	OVERLAY CHROMA-Q PLUS	103-0057	1
COM8P-10	SCREW M3x10 PH PLPS BLK Plastite	900-0024	4
COM8P-09	PCB COMPLETE M5 PLUS	113-0018	1
COM8P-08	NUT HEX M3 COMBI Bik	900-0307	2
COM8P-07	ASSY DUAL OPTICAL SWITCH 6" LEADS	100-0044	1
COM8P-06	SCREW M3x6 PH PLPS Bik	900-0017	34
COM8P-05	BELT TIMING T2.5-200	900-0656	2
COM8P-04	S/A MOTOR M5 PLUS	113-0015	2
COM8P-03	SCREW M3x12 PH PLPS Bik	900-0040	6
COM8P-02	S/A FAN M8 PLUS	114-0009	1
COM8P-01	S/A SHELF MOTORS C/W BEARINGS	114-0008	1

Parts List